

1 Product Features

- Ratiometric Linear Hall-Effect Magnetic Sensor
 - Rail-to-Rail Analog Output
 - Low Noise Output Voltage
 - Wide Operating Voltage Range: 3.0V~5.5V
 - Low Power Consumption: 4.5mA@3.3V V_{DD}
5.4mA@5.0V V_{DD}
 - Fast 30KHz Sensing Bandwidth
 - $V_{DD}/2$ Quiescent Output, Detect N-pole and S-pole magnetic fields
 - Multiple Magnetic Sensitivity Options:
 - 1.00mV/Gs KTH3101Series@ $V_{DD}=3.3V$
 - 1.65mV/Gs KTH3102Series@ $V_{DD}=3.3V$
 - 2.25mV/Gs KTH3103Series@ $V_{DD}=3.3V$
 - 3.30mV/Gs KTH3105Series@ $V_{DD}=3.3V$
 - 6.60mV/Gs KTH3110Series@ $V_{DD}=3.3V$
 - 8.90mV/Gs KTH3113Series@ $V_{DD}=3.3V$
 - 1.50mV/Gs KTH3101Series@ $V_{DD}=5V$
 - 2.50mV/Gs KTH3102Series@ $V_{DD}=5V$
 - 3.40mV/Gs KTH3103Series@ $V_{DD}=5V$
 - 5.00mV/Gs KTH3105Series@ $V_{DD}=5V$
 - 10.00mV/Gs KTH3110Series@ $V_{DD}=5V$
 - 13.50mV/Gs KTH3113Series@ $V_{DD}=5V$
 - Package: SOT23 TO-92S DFN1616
 - Operating Temperature: -40°C~125°C
 - RoHS Compliant
- ## 2 Application
- Current Sensor
 - Motor control
 - Position Detection
 - Vibration Sensor, Liquid Level Sensor
 - Proximity Switch
 - Rotary Encoder

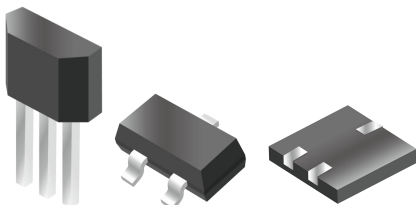

Package

3 Typical Application Schematic

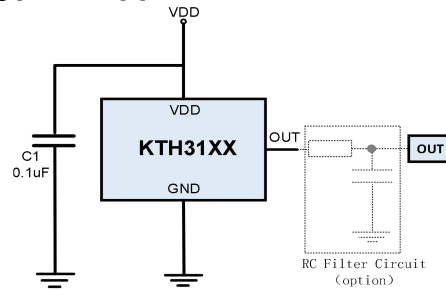

4 Descriptions

KTH31XX is a linear Hall effect sensor that can respond proportionally to the magnetic flux density. The internal circuit of KTH31XX includes a Hall sensor, a linear amplifier, and a push-pull output stage circuit. It features high-speed response and low-noise output, and achieves linear performance within a wide temperature range from -40 ° C to 125 ° C. This sensor is suitable for consumer and industrial applications requiring magnetic field detection.

The KTH31XX features high sensitivity, enabling accurate response to changes in weak magnetic fields. In the absence of a magnetic field, the analog output remains at 1/2 V_{DD} . The output varies linearly with the applied magnetic flux density, and multiple sensitivity options are available for selection. The sensor generates distinct voltage outputs for south and north magnetic poles.

The KTH31XX detects magnetic flux density perpendicular to the package top surface. It utilizes high-quality SOT23, TO-92S, and DFN1616 packages to accommodate diverse application requirements.

5 Pin Descriptions

SOT23

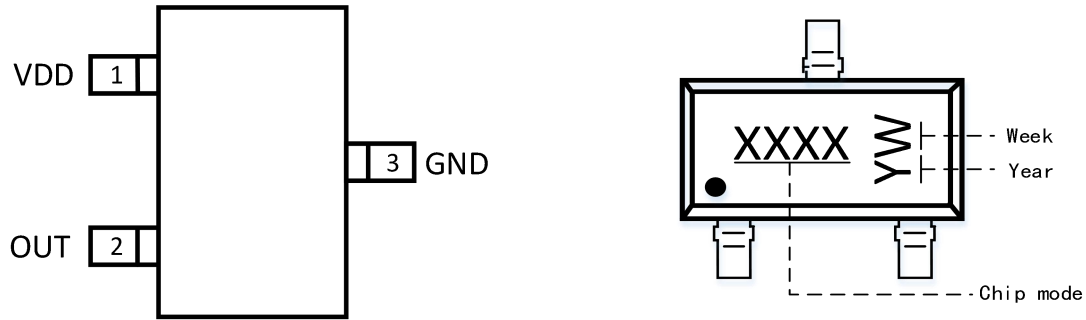

Pin Name	Pin Number	Pin Number
VDD	1	Power Supply Input
OUT	2	Output Pin
GND	3	Ground Pin

DFN1616

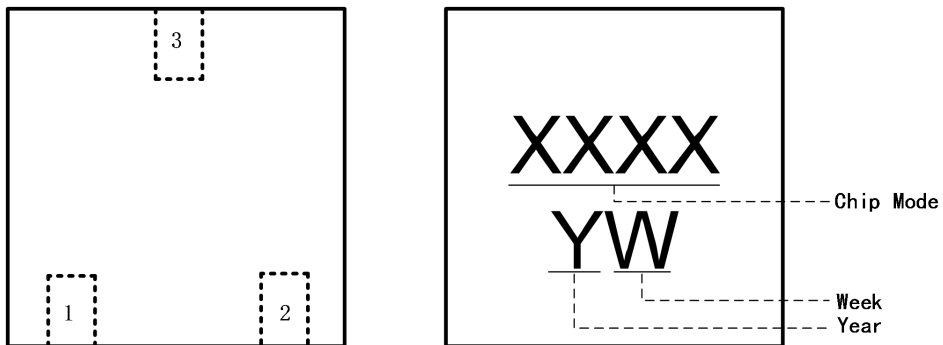

Pin Name	Pin Number	Pin Number
VDD	1	Power Supply Input
GND	2	Ground Pin
OUT	3	Output Pin

TO-92S

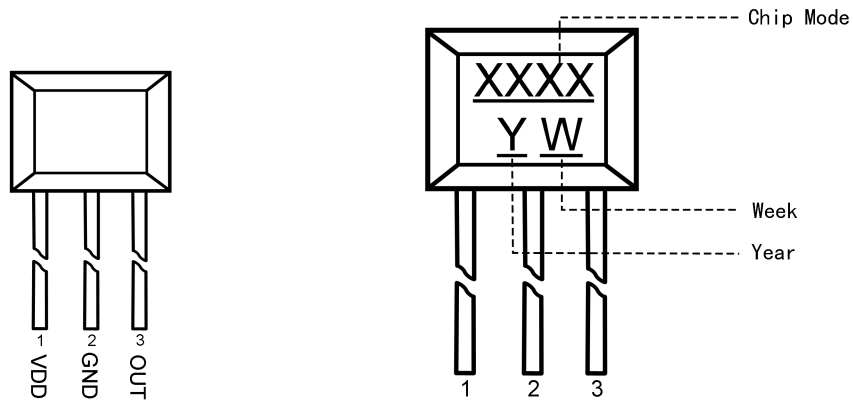

Pin Structure(Top View)

Pin Name	Pin Number	Pin Number
VDD	1	Power Supply Input
GND	2	Ground Pin
OUT	3	Output Pin

6 Block Diagram

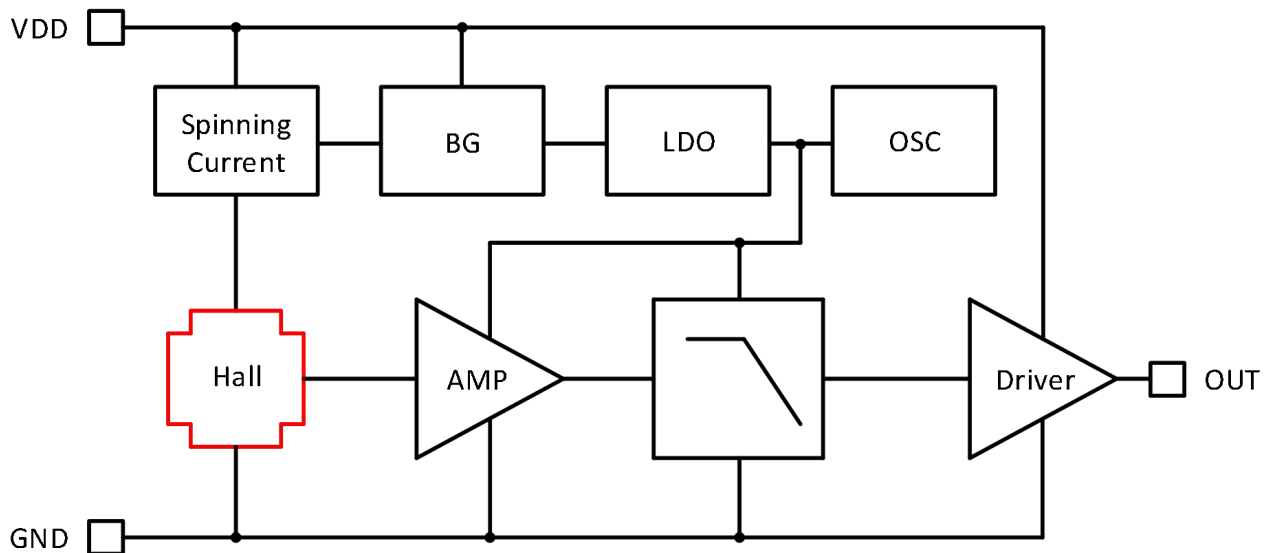

7 Output Characteristics(TA=-40°C~125°C,V_{DD}=3.0V~5.5V)

7.1 Typical Application Scenarios1

The KTH31XX can detect magnetic flux perpendicular to the top surface of the package. As shown in Table 1:When an S-pole magnetic field approaches the top surface of the chip package, the output voltage exceeds V_{DD}/2. When an N-pole magnetic field approaches the top surface of the chip package, the output voltage drops below V_{DD}/2.

Parameter	Conditions	Output
South pole	B>0 Gauss	>V _{DD} /2
North pole	B<0 Gauss	<V _{DD} /2

Table 1

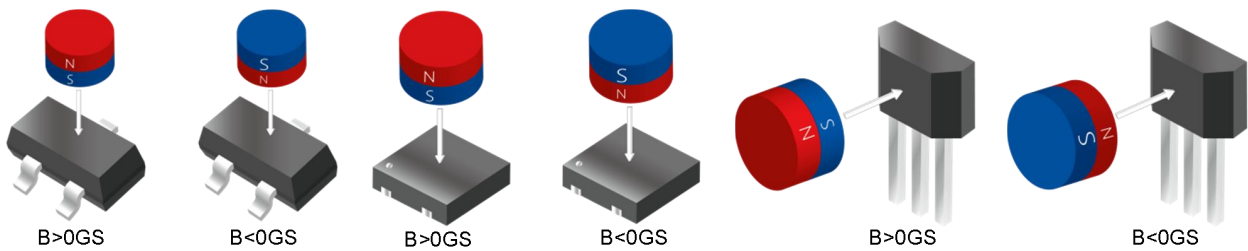

Figure 1. North Pole and South Pole approaching the front side of the chip

7.2 Typical Application Scenarios2

The KTH31XX can detect magnetic flux perpendicular to the top surface of the package. As shown in Table 2, When the magnet is positioned to the left of the chip, the output voltage of the chip is less than V_{DD}/2. As shown in Fig.3, when the magnet is directly above the chip, the output voltage equals V_{DD}/2. As shown in Fig.4, when the magnet is positioned to the right of the chip, the output voltage exceeds V_{DD}/2.

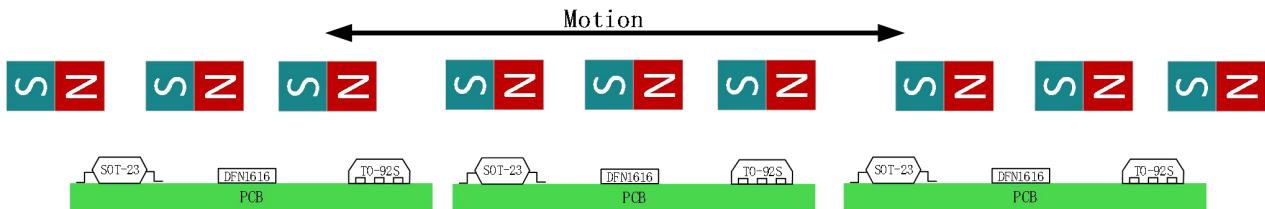
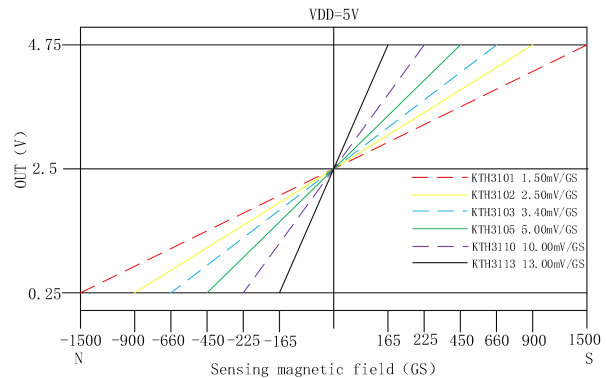
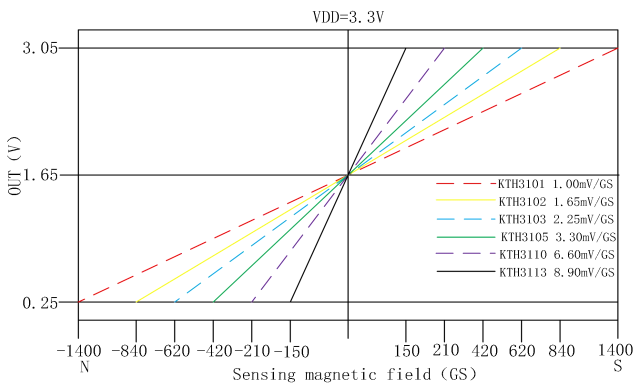

Figure2 The magnet is positioned to the left of the chip

Figure3 The magnet is positioned at the center of the chip

Figure4 The magnet is positioned to the right of the chip

7.3 Output characteristic curve



8 Product Name Structure

KTH31 XX-XXX

Package abbreviation : SS3:SOT23

DN16:DFN1616

TO3:TO-92S

Sensitivity : 01:1.00mV/Gs(@V_{DD}=3.3V) 1.50mV/Gs(@V_{DD}=5V)
 02:1.65mV/Gs(@V_{DD}=3.3V) 2.50mV/Gs(@V_{DD}=5V)
 03:2.25mV/Gs(@V_{DD}=3.3V) 3.40mV/Gs(@V_{DD}=5V)
 05:3.30mV/Gs(@V_{DD}=3.3V) 5.00mV/Gs(@V_{DD}=5V)
 10:6.60mV/Gs(@V_{DD}=3.3V) 10.00mV/Gs(@V_{DD}=5V)
 13:8.90mV/Gs(@V_{DD}=3.3V) 13.50mV/Gs(@V_{DD}=5V)

9 Absolute Maximum Ratings (@TA=+25°C, unless otherwise specified)

Symbol	Parameter	Value	Unit
V _{DD}	Supply Voltage	6.5	V
I _{OUTPUT}	Output Current	1.5	mA
V _{OUT}	Analog Output Voltage	-0.2~V _{DD} + 0.2	V
T _A	Operating temperature Range	-40~+125	°C
T _{STG}	Storage Temperature Range	-65~+150	°C
T _J	Maximum Junction Temperature	+150	°C

Note: Exceeding the absolute maximum ratings may cause permanent damage. Exposure to absolute-maximum rated conditions for extended periods may affect device reliability.

10 ESD

ESD	Value	Unit
HBM	5K	V

11 Electronics Characteristics (@TA=-40°C~125°C, VDD=3.0V~5.5V, unless otherwise specified)

KTH31XX Series						
Symbol	Parameter	Condition	Min.	Typ.	Max.	Unit
V _{DD}	Supply Voltage	Operating	3.0	3.3	5.5	V
I _{DD}	Supply Current	V _{DD} =3.3V B=0 Gs TA=25°C	—	4.5	5.5	mA
		V _{DD} =5.0V B=0 Gs TA=25°C	—	5.4	6.5	mA
I _{SC}	Sink Current	T _A =25°C	-1.5	—	1.5	mA
B _w	Bandwidth		—	30	—	KHz
T _{PO}	Power on Time	T _A =25°C	—	20	40	μs
N _F	Noise	KTH3101, V _{DD} =3.3V T _A =25°C	—	2.4	—	mV _{RMS}
		KTH3102, V _{DD} =3.3V T _A =25°C	—	3.0	—	mV _{RMS}
		KTH3103, V _{DD} =3.3V T _A =25°C	—	3.5	—	mV _{RMS}
		KTH3105, V _{DD} =3.3V T _A =25°C	—	4.8	—	mV _{RMS}
		KTH3110, V _{DD} =3.3V T _A =25°C	—	7.2	—	mV _{RMS}
		KTH3113, V _{DD} =3.3V T _A =25°C	—	8.6	—	mV _{RMS}
C _L	Output Loading Capacitance		—	—	10	nF

12 Magnetic Characteristics (@TA=-40°C~125°C, VDD=3.0V~5.5V, unless otherwise specified)

KTH31XX Series						
Symbol	Parameter	Condition	Min.	Typ.	Max.	Unit
V _Q	Quiescent Voltage	V _{DD} =3.3V, B=0, T _A =25°C	1.630	1.65	1.670	V
		V _{DD} =5.0V, B=0, T _A =25°C	2.475	2.5	2.525	V
V _Q (T)	V _Q Temperature Variation	B=0, T _A =-40°C~125°C	—	±1%*V _{DD}	—	V
V _{QRE}	Quiescent Voltage Ratio Error		—	±0.5	—	%
V _L	Output Voltage Linearity Range		0.25	—	V _{DD} -0.25	V
S _{SENS} (T)	S _{SENS} Variation Over Temperature		—	0.1	—	%/°C
S _{LE}	Sensitivity Linearity Error		-1.5	—	1.5	%
Sensitivity	Sensitivity (V _{DD} =3.3V, T _A =25°C)	KTH3101	0.93	1.00	1.07	mV/Gs
		KTH3102	1.53	1.65	1.76	mV/Gs
		KTH3103	2.10	2.25	2.41	mV/Gs
		KTH3105	3.07	3.30	3.53	mV/Gs
		KTH3110	6.14	6.60	7.06	mV/Gs
		KTH3113	8.28	8.90	9.52	mV/Gs
	Sensitivity (V _{DD} =5.0V, T _A =25°C)	KTH3101	1.40	1.50	1.61	mV/Gs
		KTH3102	2.33	2.50	2.67	mV/Gs
		KTH3103	3.16	3.40	3.68	mV/Gs
		KTH3105	4.65	5.00	5.35	mV/Gs
		KTH3110	9.30	10.00	10.70	mV/Gs
		KTH3113	12.56	13.50	14.45	mV/Gs
Magnetic Range	Magnetic Field Range (V _{DD} =3.3V)	KTH3101	—	±1400	—	Gs
		KTH3102	—	±840	—	Gs
		KTH3103	—	±620	—	Gs
		KTH3105	—	±420	—	Gs
		KTH3110	—	±210	—	Gs
		KTH3113	—	±150	—	Gs

Magnetic Range	Magnetic Field Range ($V_{DD}=5.0V$)	KTH3101	—	±1500	—	Gs
		KTH3102	—	±900	—	Gs
		KTH3103	—	±660	—	Gs
		KTH3105	—	±450	—	Gs
		KTH3110	—	±225	—	Gs
		KTH3113	—	±165	—	Gs

13 Performance Graphs

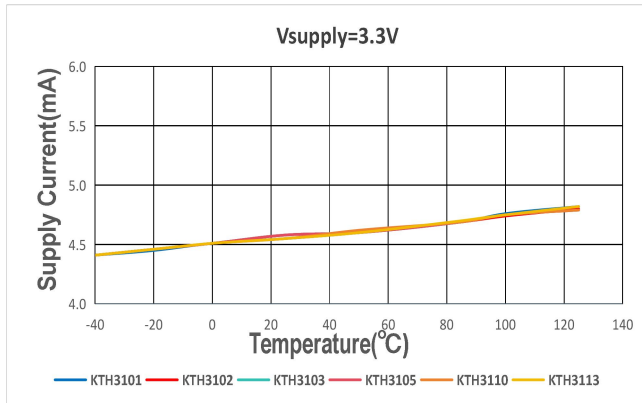

Supply Current VS Temperature @VDD=3.3V

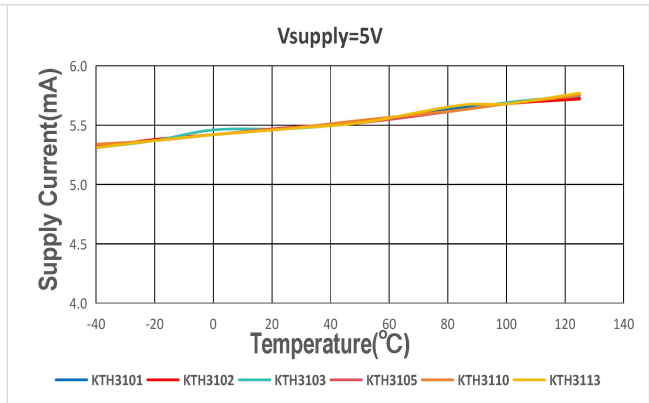

Supply Current VS Temperature @VDD=5V

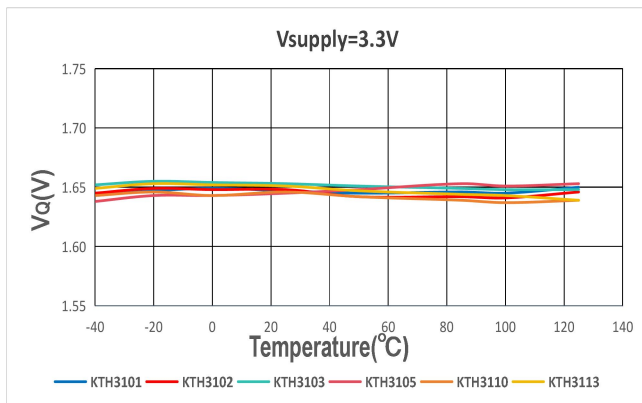

Quiescent Voltage VS Temperature @VDD=3.3V

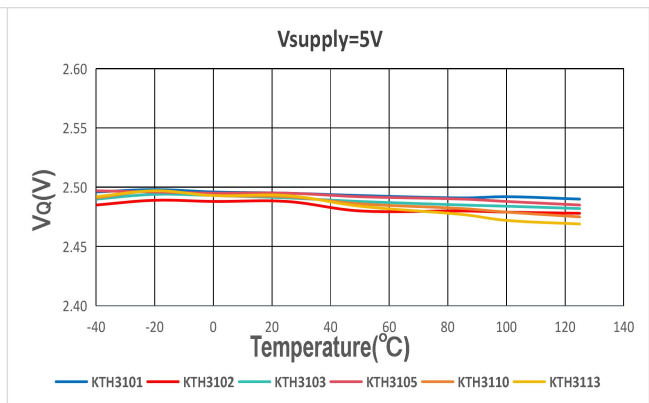

Quiescent Voltage VS Temperature @VDD=5V

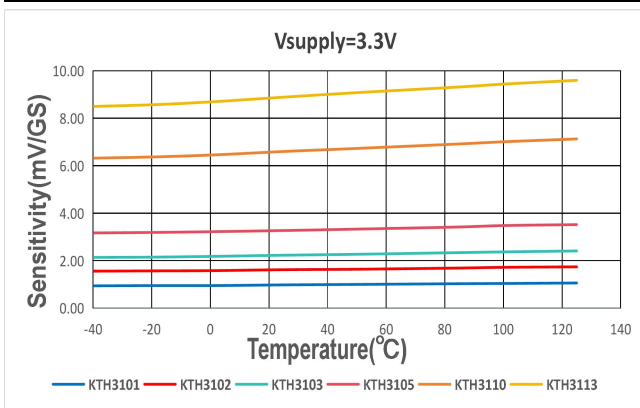

Sensitivity VS Temperature @VDD=3.3V

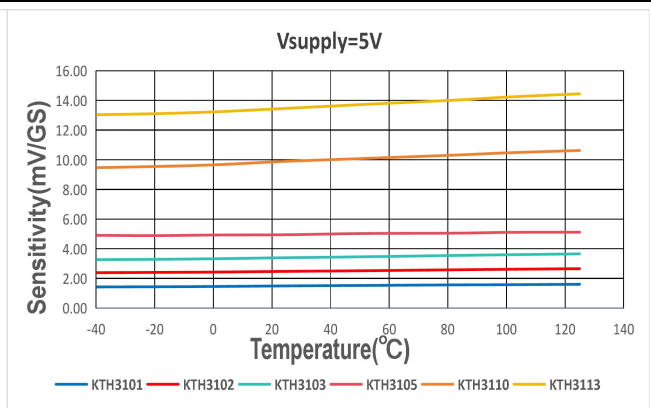

Sensitivity VS Temperature @VDD=5V

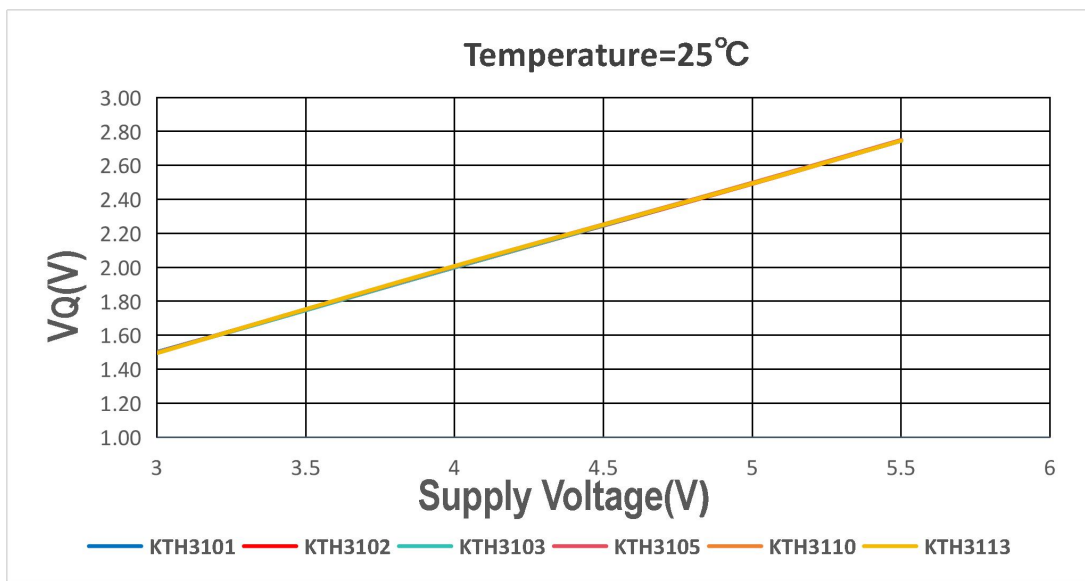

Quiescent Voltage VS Supply Voltage @TA=25°C

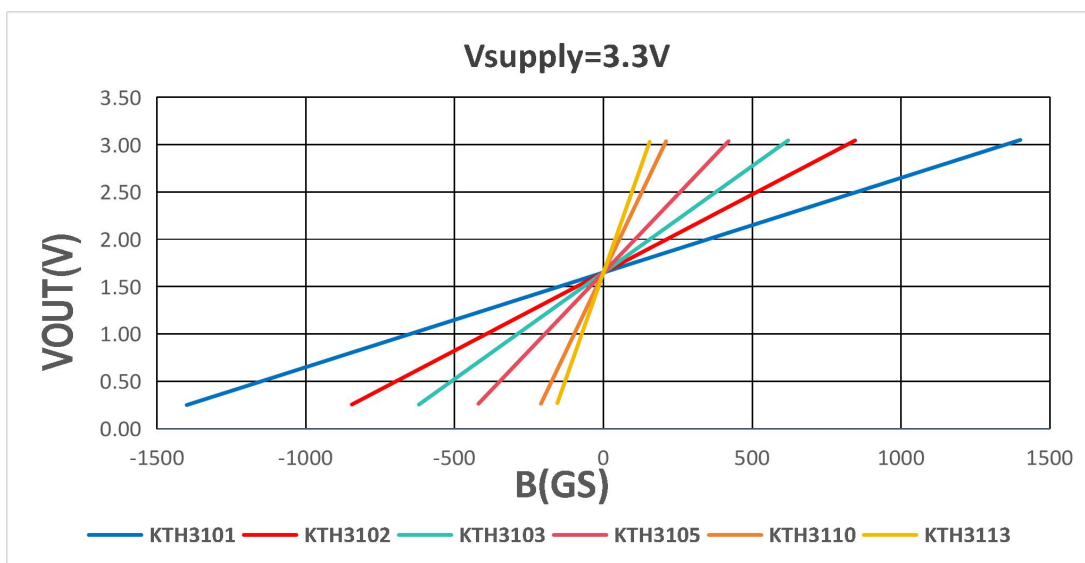

Output Voltage VS Magnetic @VDD=3.3V

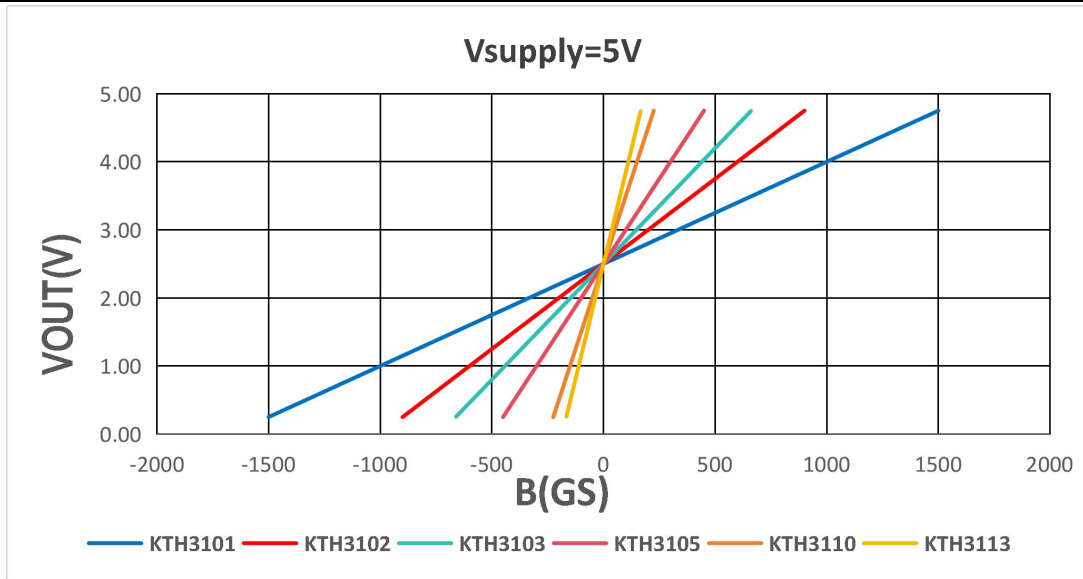

Output Voltage VS Magnetic @VDD=5V

14 Order Information

Part Numbers	Package	SQP	Number of Pins	Operating Temperature	Sensitivity (@V _{DD} =3.3V)	Sensitivity (@V _{DD} =5V)
KTH3101-SS3	SOT23	3000	3	-40°C ~ +125°C	1.00mV/Gs	1.50mV/Gs
KTH3101-DN16	DFN1616	3000	3	-40°C ~ +125°C	1.00mV/Gs	1.50mV/Gs
KTH3101-TO3	TO-92S	1000	3	-40°C ~ +125°C	1.00mV/Gs	1.50mV/Gs
KTH3102-SS3	SOT23	3000	3	-40°C ~ +125°C	1.65mV/Gs	2.50mV/Gs
KTH3102-DN16	DFN1616	3000	3	-40°C ~ +125°C	1.65mV/Gs	2.50mV/Gs
KTH3102-TO3	TO-92S	1000	3	-40°C ~ +125°C	1.65mV/Gs	2.50mV/Gs
KTH3103-SS3	SOT23	3000	3	-40°C ~ +125°C	2.25mV/Gs	3.40mV/Gs
KTH3103-DN16	DFN1616	3000	3	-40°C ~ +125°C	2.25mV/Gs	3.40mV/Gs
KTH3103-TO3	TO-92S	1000	3	-40°C ~ +125°C	2.25mV/Gs	3.40mV/Gs
KTH3105-SS3	SOT23	3000	3	-40°C ~ +125°C	3.30mV/Gs	5.00mV/Gs
KTH3105-DN16	DFN1616	3000	3	-40°C ~ +125°C	3.30mV/Gs	5.00mV/Gs
KTH3105-TO3	TO-92S	1000	3	-40°C ~ +125°C	3.30mV/Gs	5.00mV/Gs
KTH3110-SS3	SOT23	3000	3	-40°C ~ +125°C	6.60mV/Gs	10.00mV/Gs
KTH3110-DN16	DFN1616	3000	3	-40°C ~ +125°C	6.60mV/Gs	10.00mV/Gs
KTH3110-TO3	TO-92S	1000	3	-40°C ~ +125°C	6.60mV/Gs	10.00mV/Gs
KTH3113-SS3	SOT23	3000	3	-40°C ~ +125°C	8.90mV/Gs	13.50mV/Gs
KTH3113-DN16	DFN1616	3000	3	-40°C ~ +125°C	8.90mV/Gs	13.50mV/Gs
KTH3113-TO3	TO-92S	1000	3	-40°C ~ +125°C	8.90mV/Gs	13.50mV/Gs

15 Typical Application Circuit Diagram

As shown in the figure below, the Typical Application Circuit Diagram for the KTH31XX Series. Users may adopt an RC filter circuit at the output terminal to achieve lower output noise. Several common RC combination schemes, along with their corresponding output noise performance, are provided herein to facilitate user selection.

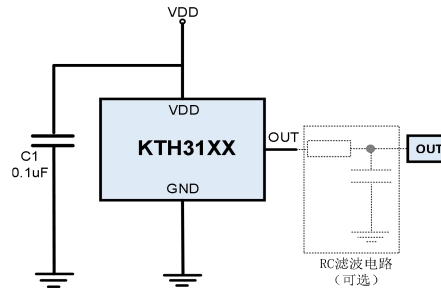

Scheme	R (Ω)	C (nF)	Condition(@VDD=3.3V)	Noise (mV _{RMS})	Bandwidth(kHZ)
1	470	15	KTH3101	1.3	22.6
			KTH3102	1.8	22.6
			KTH3103	2.2	22.6
			KTH3105	3.2	22.6
			KTH3110	4.9	22.6
			KTH3113	5.9	22.6
2	470	33	KTH3101	1	10.3
			KTH3102	1.4	10.3
			KTH3103	1.7	10.3
			KTH3105	2.5	10.3
			KTH3110	3.9	10.3
			KTH3113	4.6	10.3
3	470	68	KTH3101	0.75	4.98
			KTH3102	1.1	4.98
			KTH3103	1.3	4.98
			KTH3105	1.9	4.98
			KTH3110	2.9	4.98
			KTH3113	3.4	4.98

16 PACKAGE OUTLINE DIMENSIONS

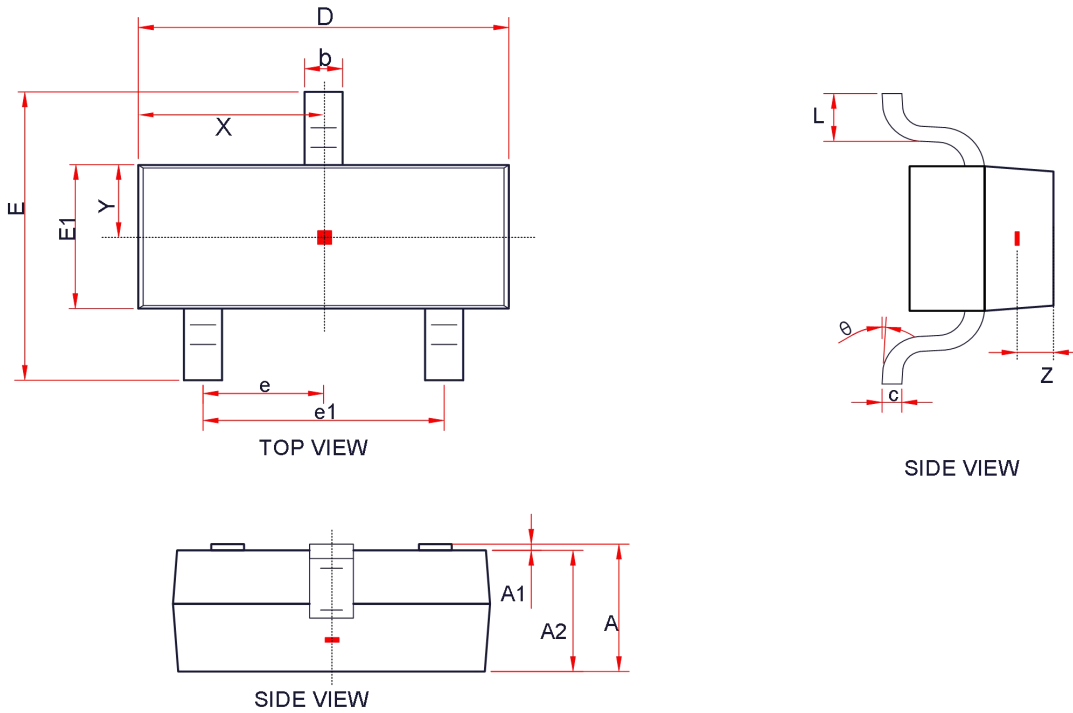

SOT23

Symbol	Dimensions in Millimeters	
	Min.	Max.
A	-	1.15
A1	0.00	0.1
A2	0.9	1.1
b	0.30	0.50
c	0.132	0.202
D	2.8	3.0
E	2.25	2.55
E1	1.2	1.4
e	0.95 TYP	
e1	1.8	2.0
L	0.30	0.50
θ	0 °	8 °
X	1.45TYP	
Y	0.65TYP	
Z	0.3TYP	

DFN1616

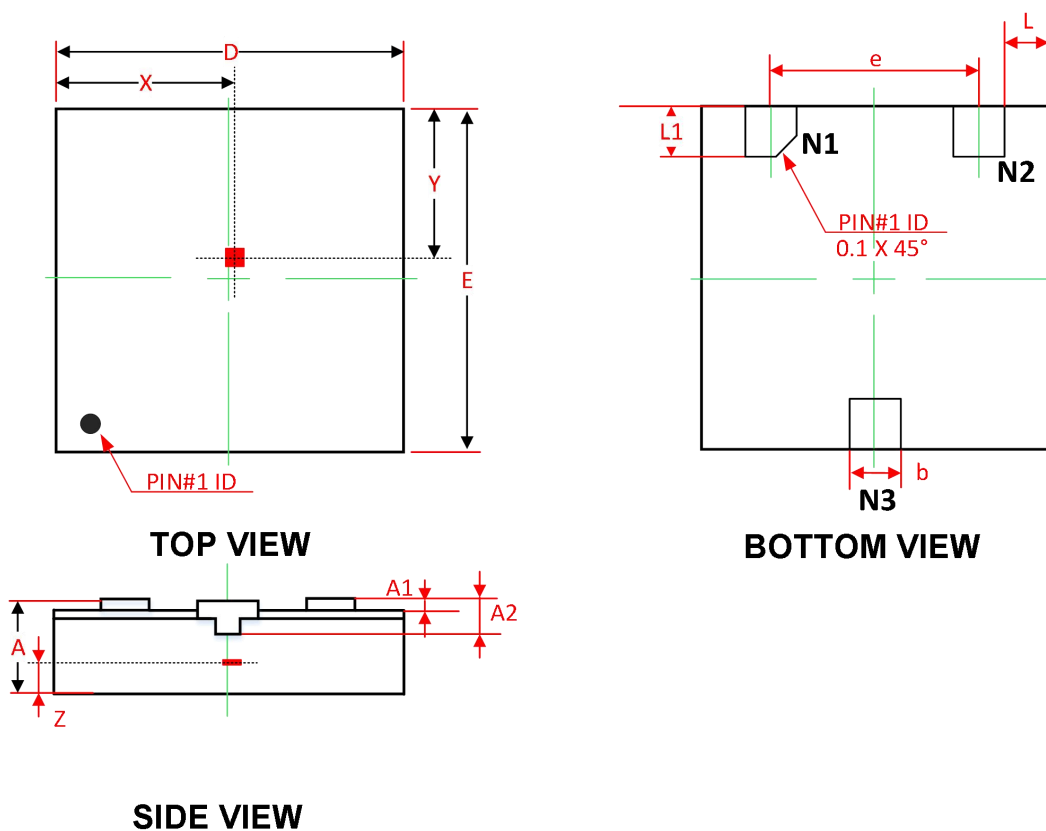

Symbol	Dimensions in Millimeters		
	Min.	Typ.	Max.
A	0.450	-	0.550
A1	0.000	-	0.050
A2	0.150 REF.		
D	1.550	-	1.650
E	1.550	-	1.650
b	0.200	-	0.300
e	0.950	-	1.050
L	0.175 REF.		
L1	0.200	-	0.300
X	-	0.9	-
Y	-	0.7	-
Z	-	0.185	-

TO-92S

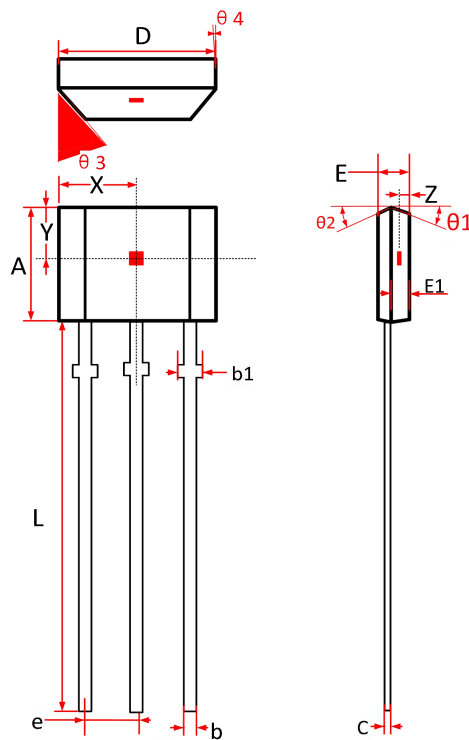

Symbol	Dimensions in Millimeters		
	Min.	Typ.	Max.
A	2.90	3.00	3.10
b	0.35	0.39	0.50
b1	0.40	0.44	0.55
C	0.36	0.38	0.45
D	3.90	4.00	4.10
E	1.42	1.52	1.62
E1	-	0.75	-
e	1.27 TYP		
L	13.50	14.50	15.50
theta 1	-	6°	-
theta 2	-	3°	-
theta 3	-	45°	-
theta 4	-	3°	-
X	-	2	-
Y	-	1.3	-
Z	-	0.43	-