

KTH5701 series

Low power, high accuracy 3D Hall sensor



1 Features

- 3D (X, Y, Z-axis) Magnetic Field Output
- CORDIC Algorithm Angle Output
- XY Axis Typical Working Range $\pm 130\text{mT}$ Note1
- Z-axis Typical Working Range $\pm 80\text{mT}$
- T (temperature) Output
- Support Absolute Position Detection
- XY XZ YZ Axis Plane Angle Output
- High-Precision 16 Bit ADC Output
- Support Push Button Detect Function
- SPI or I2C Optional Communication Interface
- Support Wake-up and Measurement Trigger Mode
- Working Voltage 2.8V ~ 5.5V
- AQ2 Industrial Grade Working Temperature $-40 \sim +105^\circ\text{C}$
- AQ3 Consumer Grade Working Temperature $-40 \sim +85^\circ\text{C}$

Note 1: When using the angle output function of the chip, it is recommended that the magnetic flux density of both axes of this plane is greater than 20mT.

2 Typical Application

- Agricultural Irrigation
- Knob & Remote Lever
- Linear Position Detection
- 3D Position Angle Detection
- Non-Contact Magnetic Field Measurement
- Low Power Consumption Magnetic Encoder

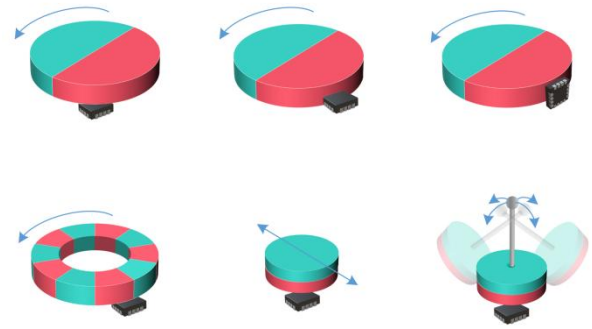

3 Overview

KTH5701 is a 3D Hall chip with digital output, which integrates three independent Hall sensors for X-axis, Y-axis and Z-axis respectively. The signal chain uses a high-precision op amp to convert the analog signal into a digital output through a 16-bit ADC. The external master can read out the measurement data in SPI or I2C modes. In addition, a temperature sensor is integrated inside the chip for temperature compensation of the magnetic field.

KTH5701 supports a variety of operating modes such as continuous sensing mode, wake-up & Sleep mode and single conversion mode, which are suitable for different application scenarios. The BUTT_OUT pin is used to detect the push button function between the magnet and the chip, and can also be configured for Trigger mode, which triggers a single measurement.

At the same time, KTH5701 integrates the CORDIC algorithm and supports the angular output of the plane (XY plane, XZ plane, YZ plane). Increasing the amplitude adjustment register greatly facilitates two common rotary application scenarios end of shaft and out of shaft. Support the magnetic field threshold detection corresponding to the selected plane (XY plane, XZ plane, YZ plane), and the same chip can detect knobs and buttons at the same time.

This product has the characteristics of high integration and flexible application, and is widely used in various application scenarios.

KTH5701 series

Low power, high accuracy 3D Hall sensor



4 Functional Diagram

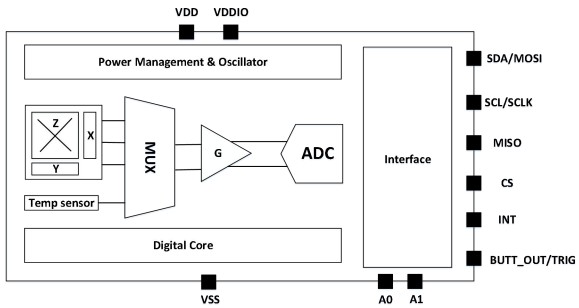

Device Information

Model	Package	Package Size (Nominal)
KTH5701	QFN3x3-16L	3.00mm x 3.00mm
KTH5701	DFN2x2.5-8L	2.00mm x 2.50mm

Catalog

1 Features	1	11 Data Read Frame	20
2 Typical Application	1	11.1 TXYZ Read Back Method	21
3 Overview	1	11.2 TABZ Read Back Method	24
4 Functional Diagram	2	12 SPI Communication Mode	28
5 Pin Configuration and Functions	4	13 I2C Communication Mode	29
5.1 QFN3x3-16L	4	14 Special Pin Description	30
5.2 DFN2x2.5-8L	5	15 Read and Write Register Description	31
6 Specifications	6	15.1 SPI Communication	31
6.1 Absolute maximum ratings	6	15.2 I2C Communication	32
6.2 Recommend Operating Conditions	6	16 Register Map Description	33
6.3 Electrical Characteristics	6	17 OTP Programming	45
6.4 Magnetic Properties	7	18 QFN_16PIN Package Dimensions	46
6.5 Timing Parameter	8	18.1 QFN3x3-16L package	46
6.6 Update rate settings	9	18.2 DFN2x2.5-8L package	48
7 Magnetic Field Sensing Direction	10	19 Reference Circuit	49
8 Measurement Mode Description	11	19.1 QFN3x3-16L package SPI	49
8.1 Continuous Sensing Mode	11	19.2 QFN3x3-16L package I2C	50
8.2 Wake-up & Sleep Mode	13	19.3 DFN2x2.5-8L package I2C	50
8.3 Single Conversion Mode	14	20 Order Information	50
8.4 Idle Mode	15	21 Strap and Reel Information	51
9 Reset	17	21.1 QFN3x3-16L	51
10 Operating Status Description	18	21.2 DFN2x2.5-8L	53

5 Pin Configuration and Functions

5.1 QFN3x3-16L

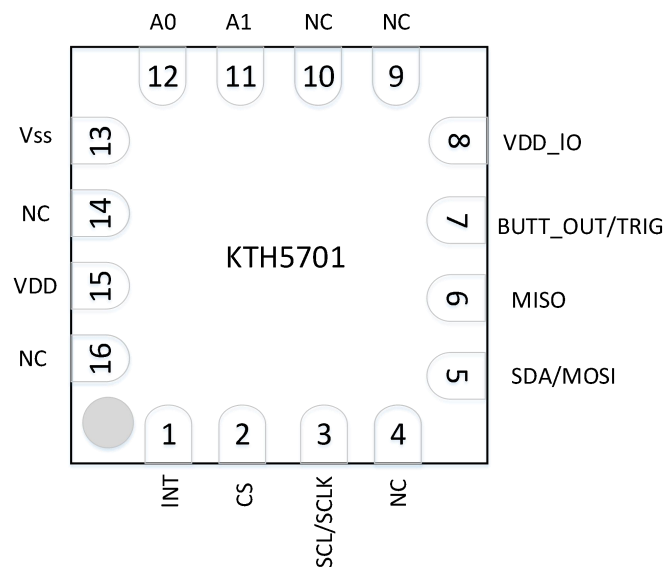

figure5-1. QFN3x3 16-Pin Top view

table5-1. Pin Configuration and Functions

Pin No.	Name	Description	Type
1	INT	Data Ready or Wake-up & Sleep Mode Interrupt Signal	Output
2	CS	In I2C communication protocol, pull up to VDD_IO In SPI communication protocol, controlled by SPI master, active-low levels	Input
3	SCL/SCLK	I2C or SPI Clock Signal	Input
5	SDA/MOSI	I2C data input and output port SPI Data, Master Output Slave Input	Input/Output
6	MISO	SPI Data, Master Input Slave Output When using only the SPI three-PIN data transfer, MISO and MOSI need to be short-circuited	Output
7	BUTT_OUT/TRIG	BUTT_OUT Button Function Output or TRIG Single Measurement Signal When this pin function is not used, this pin must be connected to ground	Input/Output
8	VDD_IO	IO Power Supply	Power Supply
11	A1	I2C Address Input Port A1 In SPI communication protocol, this pin must be connected to ground	Input

KTH5701 series

Low power, high accuracy 3D Hall sensor



12	A0	I2C Address Input Port A0 In SPI communication protocol, this pin must be connected to ground	Input
13	VSS	Ground	Ground
15	VDD	Power Supply	Power Supply
Other	NC	Not Connect It is recommended that all NC pins be grounded	Non

Note: When the BUTT_OUT/TRIG pin function is not used, this pin must be connected to ground. In SPI communication protocol, A1 and A0 pins must be connected to ground. It is recommended that all NC pins be grounded.

5.2 DFN2x2.5-8L

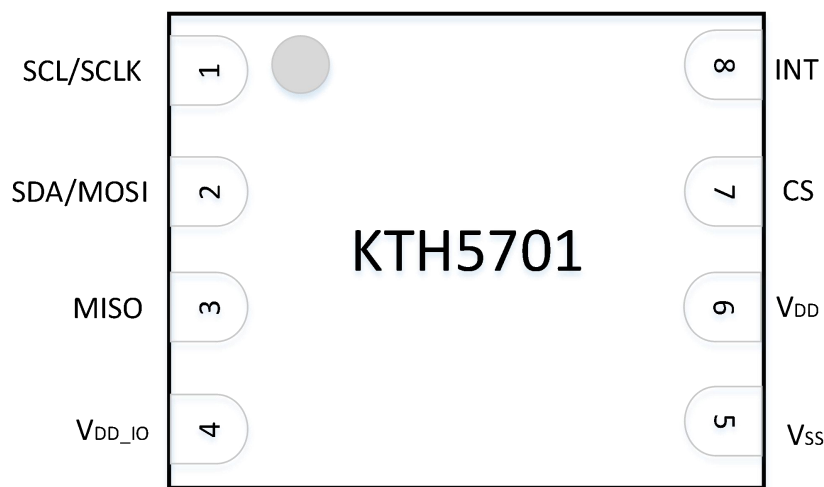

figure5-2. DFN2x2.5 8-Pin Top view

table5-2. Pin Configuration and Functions

Pin No.	Name	Description	Type
1	SCL/SCLK	I2C or SPI Clock Signal	Input
2	SDA/MOSI	I2C data input and output port SPI Data, Master Output Slave Input	Input/Output
3	MISO	SPI Data, Master Input Slave Output When using only the SPI three-PIN data transfer, MISO and MOSI need to be short-circuited	Output
4	VDD_IO	IO Power Supply	Power Supply
5	VSS	Ground	Ground
6	VDD	Power Supply	Power Supply
7	CS	In I2C communication protocol, pull up to VDD_IO In SPI communication protocol, controlled by SPI master, active-low levels	Input
8	INT	Data Ready or Wake-up & Sleep Mode Interrupt Signal	Output

KTH5701 series

Low power, high accuracy 3D Hall sensor



6 Specifications

The following parameters are measured at room temperature 25°C.

6.1 Absolute maximum ratings

Parameter	Description	Min.	Max.	Unit
V _{DD_MAX}	Supply Voltage Limits	-0.3	6	V
V _{DD_IO_MAX}	Digital IO Supply Limits	-0.3	6	V
T _{storage}	Maximum Storage Temperature		150	°C
V _{ESD}	ESD (HBM)		±5K	V

6.2 Recommend Operating Conditions

Parameter	Description	Min.	Typ.	Max.	Unit
V _{DD}	Supply Voltage	2.8	3.3	5.5	V
V _{DD_IO}	Digital IO Supply Voltage	1.8		V _{DD}	V
V _{IH}	Input High Level Voltage	0.75			V _{DD_IO}
V _{IL}	Input Low Level Voltage			0.25	V _{DD_IO}
T _{OPERATION}	AQ2 Industrial Grade Operating Temperature	-40	25	105	°C
T _{OPERATION}	AQ3 Consumer Grade Operating Temperature	-40	25	85	°C

6.3 Electrical Characteristics

Parameter	Description	Conditions	Min.	Typ.	Max.	Unit
V _{DD}	Supply Voltage		2.8	3.3	5.5	V
V _{DD_IO}	Digital IO Supply Voltage		1.8		V _{DD}	V
I _{DD,CONVXY}	Conversion Current X-axis or Y-axis	V _{DD} =3.3V		4.89		mA
I _{DD,CONVZ}	Conversion Current			3.87		mA

KTH5701 series

Low power, high accuracy 3D Hall sensor



	Z-axis				
I _{DD,CONVT}	Conversion Current Temperature			2.58	mA
I _{DD,STBY}	Standby Current			61.7	μ A
I _{DD,WAKE_STBY}	Wake-Up & Sleep Standby Current			2.4	μ A
I _{DD,IDLE}	Idle Current			1.4	μ A

6.4 Magnetic Properties

Parameter	Description	Conditions	Min.	Typ.	Max.	Unit
M _{xyrange}	Magnetic Flux Density Linear Range		-130		130	mT
M _{Zrange}	Magnetic Flux Density Linear Range	@gain=20	-80		80	mT
SENS _x	X-axis Sensitivity			65.5		LSB/mT
SENS _y	Y-axis Sensitivity			65.5		LSB/mT
SENS _z	Z-axis Sensitivity			102		LSB/mT
N _{RMSxy}	XY Axis RMS Noise	@gain=20 magnOsr=0 digCtrl=0		0.2		mT
N _{RMSxy}	XY-Axis RMS Noise	@gain=20 magnOsr=3 digCtrl=0		0.03		mT
N _{RMSxy}	XY-Axis RMS Noise	@gain=20 magnOsr=3 digCtrl=4		0.01		mT
N _{RMSz}	Z-Axis RMS Noise	@gain=20 magnOsr=0 digCtrl=0		0.1		mT
N _{RMSz}	Z-Axis RMS Noise	@gain=20 magnOsr=3 digCtrl=0		0.02		mT
N _{RMSz}	Z-Axis RMS Noise	@gain=20 magnOsr=3 digCtrl=4		0.01		mT
A _{ERR_xy}	XY Plane Rotation 360 ° Angle	@B=40mT		± 1		Degree

KTH5701 series

Low power, high accuracy 3D Hall sensor



	Error	magnOsr=3 digCtrl=4				
A _{ERR_xz}	XY Plane Rotation 360 ° Angle Error				± 1	Degree
A _{ERR_yz}	XY Plane Rotation 360 ° Angle Error				± 1	Degree

The above parameters are measured at 25° C

6.5 Timing Parameter

Parameter	Description	Min.	Typ.	Max.	Unit
T _{start}	Start Up Time		4		ms
T _{CONVM}	Single Magnetic axis Conversion Time (Programmable)	165		33349	μ s
		$69+32*2^{\text{magnOsr}} * (2+2^{\text{digCtrl}})$			μ s
T _{CONVT}	Temperature Conversion Time (Programmable)	165		837	μ s
		$69+96*2^{\text{tempOsr}}$			μ s
T _{CONV_END}	Time to end analog active mode		108		μ s
T _{active}	Time from IDLE to ACTIVE		220		μ s
T _{Continuous}	When measTime=0 , time from continuous sensing mode to finish one Single Measurement	$m*T_{CONVM} + T_{CONVT} + T_{CONV_END}$			μ s
T _{wakeUp}	When measTime=0, time from wake-up & Sleep mode to finish one single measurement	$T_{active} + m*T_{CONVM} + T_{CONVT} + T_{CONV_END}$			μ s
T _{single}	Time from turns on the single conversion mode	$T_{active} + m*T_{CONVM} + T_{CONVT} + T_{CONV_END}$			μ s

KTH5701 series

Low power, high accuracy 3D Hall sensor



	to complete one single measurement		
--	------------------------------------	--	--

The above parameters are measured at 25° C

Note:

- m in the above table represents the number of gating items measured from the magnetic field. If you choose to measure the XY axis, m=2. If the XYZ axis is gated, m=3.

6.6 Update rate settings

The update rate of KTH5701 is related to the settings of the magnOsr and digCtrl bits in the 0x1C register. The table below lists the measurement rates of the chip under different magnOsr and digCtrl settings

Measurement Axis	magnOsr	digCtrl	Update Rate		
			Single Axis	Two Axes	Three Axes
X, Y, Z Axis	0	0	3.66 kHz	2.28 kHz	1.65 kHz
X, Y, Z Axis	1		2.71 kHz	1.58 kHz	1.12 kHz
X, Y, Z Axis	2		1.78 kHz	0.98 kHz	0.68 kHz
X, Y, Z Axis	3		1.05 kHz	0.56 kHz	0.38 kHz
X, Y, Z Axis	0	1	3.27 kHz	1.99 kHz	1.43 kHz
X, Y, Z Axis	1		2.30 kHz	1.31kHz	0.92 kHz
X, Y, Z Axis	2		1.45 kHz	0.78 kHz	0.54 kHz
X, Y, Z Axis	3		0.83 kHz	0.43 kHz	0.29 kHz
X, Y, Z Axis	0	2	2.71 kHz	1.58 kHz	1.12 kHz
X, Y, Z Axis	1		1.78 kHz	0.98 kHz	0.68 kHz
X, Y, Z Axis	2		1.05 kHz	0.56 kHz	0.38 kHz
X, Y, Z Axis	3		0.58 kHz	0.30 kHz	0.20 kHz
X, Y, Z Axis	0	3	2.01 kHz	1.12 kHz	0.78 kHz
X, Y, Z Axis	1		1.22 kHz	0.65 kHz	0.44 kHz
X, Y, Z Axis	2		0.68 kHz	0.35 kHz	0.24 kHz
X, Y, Z Axis	3		0.36 kHz	0.18 kHz	0.12 kHz
X, Y, Z Axis	0	4	1.32 kHz	0.71 kHz	0.48 kHz
X, Y, Z Axis	1		0.75 kHz	0.39 kHz	0.26 kHz
X, Y, Z Axis	2		0.40 kHz	0.20 kHz	0.13 kHz
X, Y, Z Axis	3		0.20 kHz	0.10 kHz	0.070 kHz
X, Y, Z Axis	0	5	0.79 kHz	0.41 kHz	0.27 kHz
X, Y, Z Axis	1		0.42 kHz	0.21 kHz	0.14 kHz
X, Y, Z Axis	2		0.22 kHz	0.11 kHz	0.074 kHz
X, Y, Z Axis	3		0.11 kHz	0.056 kHz	0.037 kHz
X, Y, Z Axis	0	6	0.43 kHz	0.22 kHz	0.15 kHz
X, Y, Z Axis	1		0.22 kHz	0.11 kHz	0.077 kHz

KTH5701 series

Low power, high accuracy 3D Hall sensor



X, Y, Z Axis	2	7	0.11 kHz	0.058 kHz	0.038 kHz
X, Y, Z Axis	3		0.058 kHz	0.029 kHz	0.019 kHz
X, Y, Z Axis	0		0.23 kHz	0.11 kHz	0.078 kHz
X, Y, Z Axis	1		0.11 kHz	0.059 kHz	0.039 kHz
X, Y, Z Axis	2		0.059 kHz	0.029 kHz	0.019 kHz
X, Y, Z Axis	3		0.029 kHz	0.014 kHz	0.009 kHz

7 Magnetic Field Sensing Direction

The KTH5701 can sense magnetic fields from the X, Y and Z axis directions. Hall elements in the XY direction are sensitive to magnetic fields parallel to the package, and Z-direction elements are sensitive to magnetic fields perpendicular to the package. As shown in Figure 7-1, Hall elements in each direction are sensitive to both N and S poles. The chip output value is an unsigned number.

When the chip is in a non-magnetic environment, the output value of the three-axis magnetic field is 32768.

When the direction of the magnetic field is consistent with the direction of the arrow as shown in the figure, the output value of this axis is greater than 32768.

When the direction of the magnetic field is opposite to the direction of the arrow as shown in the figure, the output value of this axis is less than 32768.

Note:

The sensor output 32768 under the above non-magnetic condition does not take into account the effects of Hall device and signal chain offset, temperature drift and noise.

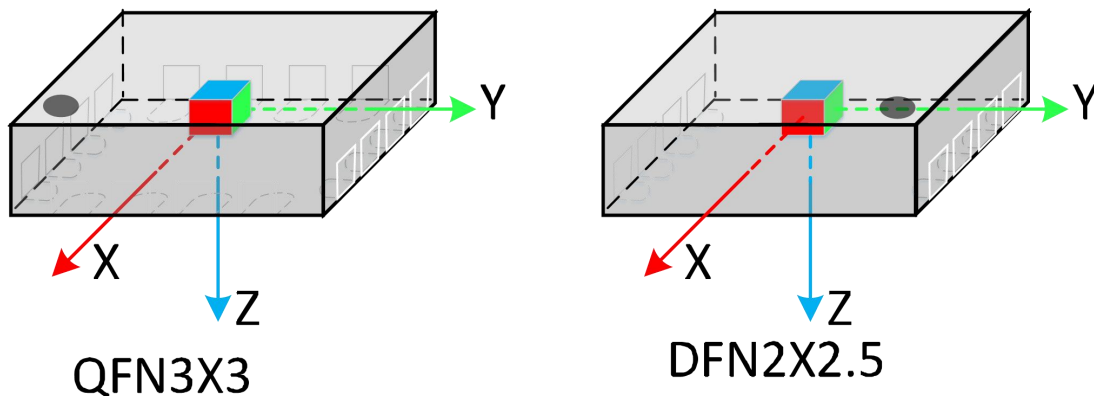

Figure 7-1. Schematic diagram of the sensitive direction of each axis producing the ADC positive output

KTH5701 series

Low power, high accuracy 3D Hall sensor

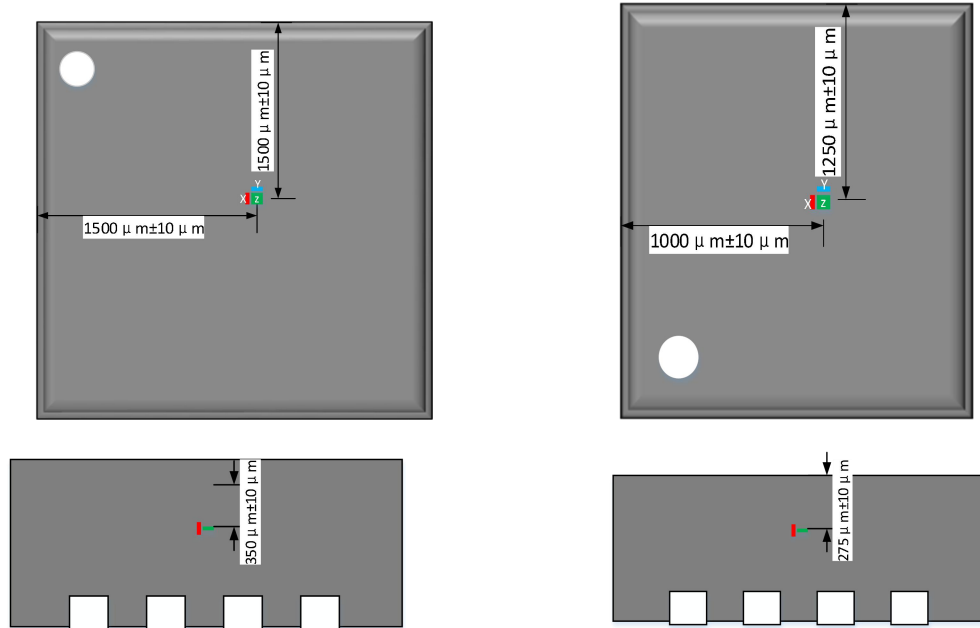

Figure 7-2. The relative position of sensitive area in the QFN3x3 16-Pin package

8 Measurement Mode Description

KTH5701 supports a variety of working modes. This product can be used in three modes: continuous sensing mode, wake-up & Sleep mode, single conversion mode.

Measurement Function	Function Introduction
Continuous Sensing Mode	Continuously measures the gated channel in the ZYXT
Wake-up & Sleep Mode	When the difference between the current measurement item ZYX and the set reference value is greater than the set threshold in the corresponding register, the chip will set the INT pin to 1
Single Conversion Mode	Make a single measurement of the gated channel in the ZYXT
Idle Mode	Exit the current mode and enter the idle state

Table 8-1

8.1 Continuous Sensing Mode

KTH5701 series

Low power, high accuracy 3D Hall sensor

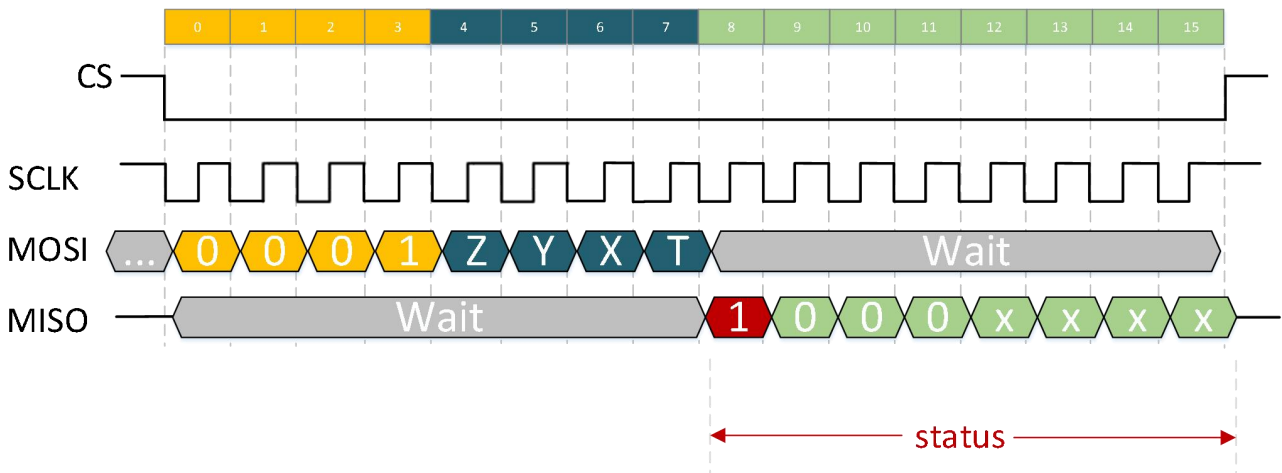

Figure 8-1. Continuous Sense Mode SPI Communication Diagram

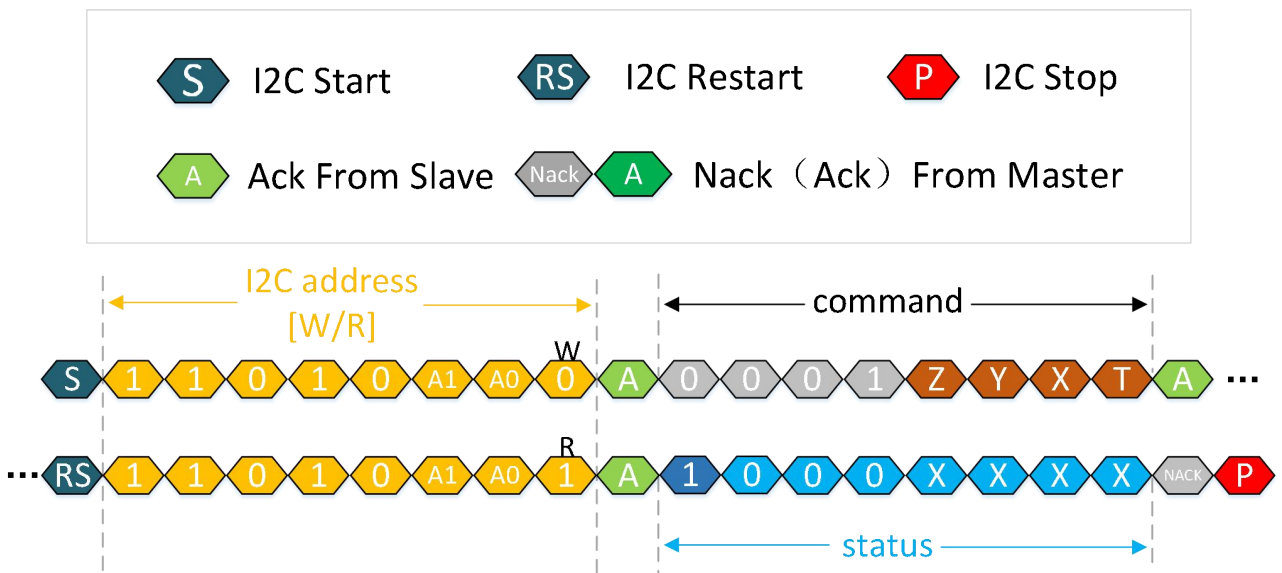

Figure 8-2. Continuous Sensing Mode I2C Communication Diagram

After the host sends a command of continuous sensing mode to the chip, the chip will continue to measure the measurement item (ZYXT) selected by the host until the host sends an idle mode command. The selection of the measurement item is related to the last four bits of the command sent by the host. The sequence of the corresponding second nibble is ZYXT, and the corresponding bit is set to 1 to measure the measurement item. If the host sends the binary command 00011001 to the chip, the chip enters the continuous sensing mode, and continuously measures the two measurement items of ZT until the host sends the idle mode command .

In scenarios where a large amount of magnetic field/temperature data around the chip needs to be continuously obtained, and the power consumption requirements are not too strict, the continuous sensing mode is recommended. When the chip turns on the continuous sensing mode, the method of intermittent measurement is used to reduce the power consumption of the chip.

The chip will automatically and continuously turn on the measurement of the corresponding measurement item, and the interval between two adjacent measurements is controlled by measTime. TempOsr, magnOsr and digCtrl control

KTH5701 series

Low power, high accuracy 3D Hall sensor



the measurement time of corresponding measurement items.

8.2 Wake-up & Sleep Mode

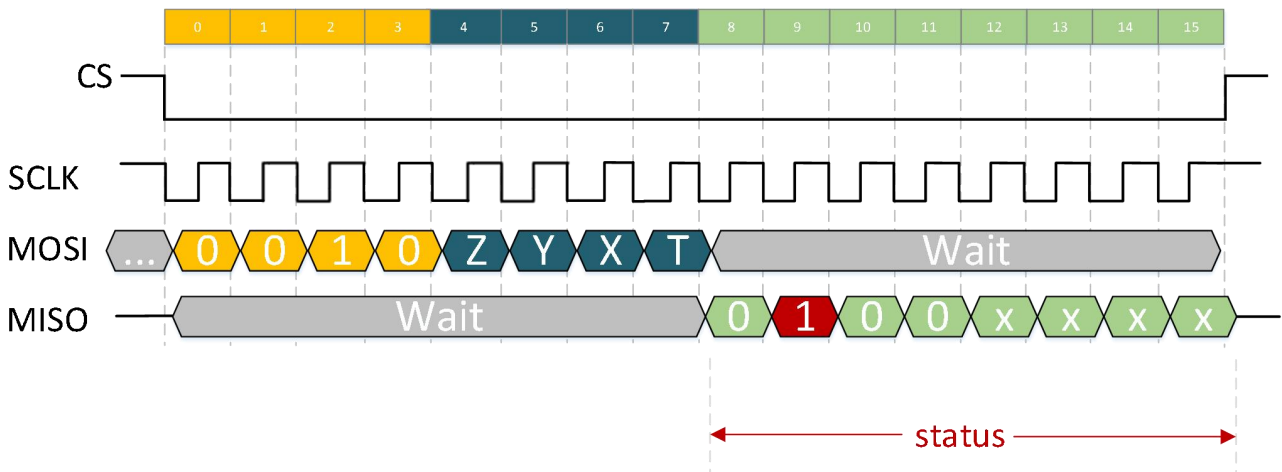

Figure 8-3. Wake-up & Sleep Mode SPI Communication Diagram

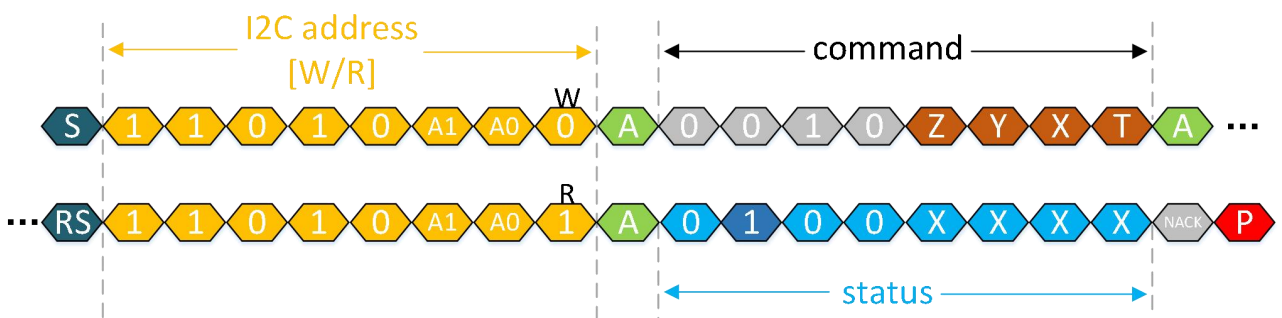
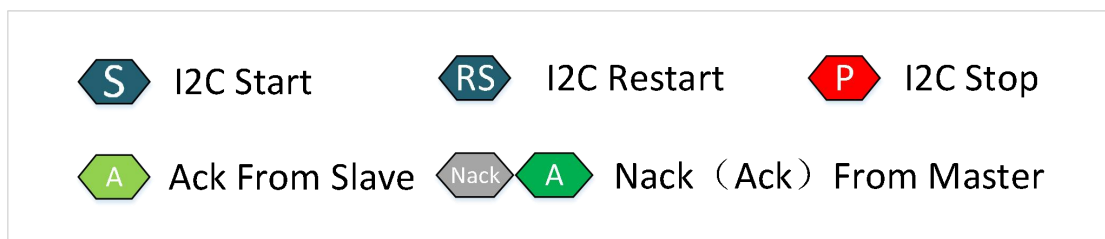

Figure 8-4. Wake-up & Sleep Mode I2C Communication Diagram

After the host sends a wake-up & Sleep mode command to the chip, the chip will be in a low-power measurement mode and measure the measurement item (ZYXT) selected by the host at a certain frequency until the host sends an idle mode command. The selection of the measurement item is related to the last four bits of the command sent by the host. The sequence of the corresponding second nibble is ZYXT, and the corresponding bit is set to 1, and the measurement item is measured once. If the host sends the binary command 00101000 to the chip, the chip enters the wake-up & Sleep mode, and continuously measures the measurement item of Z until the host sends the idle mode command. When the chip is in wake-up & Sleep mode, the data Read Frame can be used to read the measurement data of any strobe item, but the T strobe does not have a threshold wake-up function, and only XYZ three items have a threshold wake-up function, that is, after the T detected by the chip changes, the threshold change signal will not be generated at the INT pin.

After the chip starts the wake-up & Sleep mode, when the intensity of a measurement item around the chip changes, and the difference between the current intensity and the reference value exceeds the value set in the threshold register, the chip INT pin will be pulled high. After the host reads the measurement data back at one time through Data Read Frame, the INT pin is pulled low, otherwise it remains high. The INT pin of the chip will not actively pull down, that is, the difference between the intensity of the measured item and the reference value at a certain moment exceeds the set threshold. After the INT pin is pulled high, if the intensity of the measured item is weakened at the next moment, the difference is lower than the set threshold, but the host does not read back the measurement data, the INT pin will not actively pull down.

For example, the chip sends a wake-up & Sleep mode command (0x28). If the difference between the Z-axis magnetic flux density around the chip and the reference value at a certain moment exceeds the value set in the Z-axis threshold register (wzTh), then the INT pin is pulled high at this time. After the host reads the measurement data back at one time through Data Read Frame, the INT pin is pulled low, otherwise it remains high. Even if the magnetic flux density of the Z-axis around the chip is weakened again, the difference from the reference value is lower than the value set in the corresponding register of the Z-axis, and the INT pin remains at a high level before the host reads back.

The setting of the reference value is related to the configuration in the wake-up & Sleep mode related registers, wakeSel in reg 0x1C, wakeDiff in reg 0x1D, see the register description for details.

8.3 Single Conversion Mode

KTH5701 series

Low power, high accuracy 3D Hall sensor

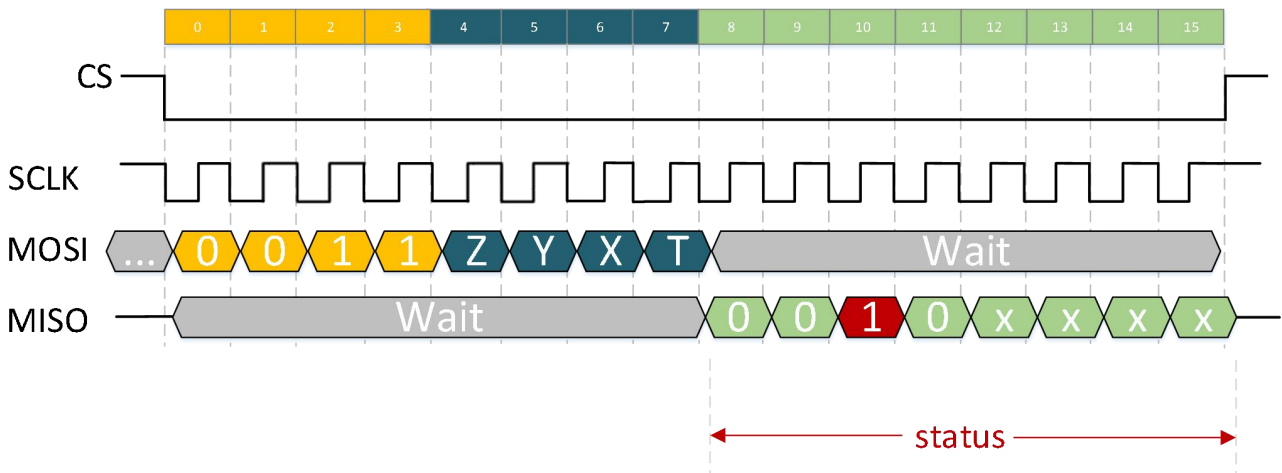

Figure 8-5. Single Conversion Mode SPI Communication Diagram

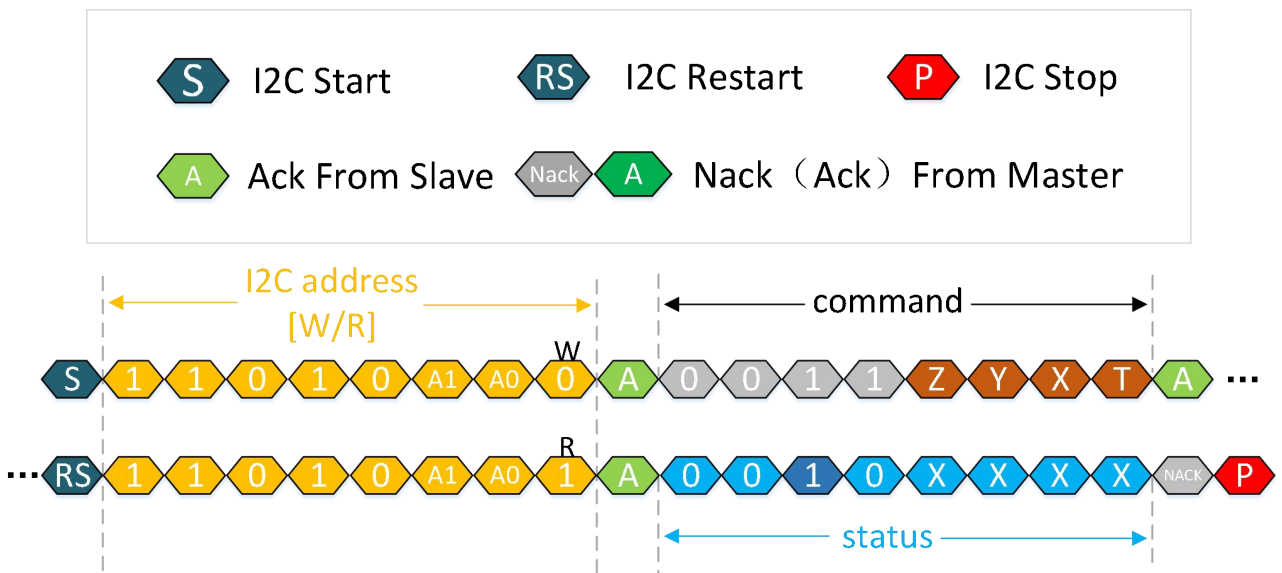

Figure 8-6. I2C Communication Diagram in Single Conversion Mode

After the host sends a single Conversion mode command to the chip, the chip will measure the measurement item (ZYXT) selected by the host once and automatically return to the idle state. The effect is equivalent to sending the Idle Mode command, that is, the chip receives for single conversion mode command, after completing one measurement, it is not necessary to send the Idle Mode command to return to the idle mode. The selection of the measurement item is related to the last four bits of the command sent by the host. The sequence of the corresponding second nibble is ZYXT, and the corresponding bit is set to 1, and the measurement item is measured once. If the host sends the binary command 00111001 to the chip, the chip will measure the two measurement items of ZT once.

8.4 Idle Mode

KTH5701 series

Low power, high accuracy 3D Hall sensor

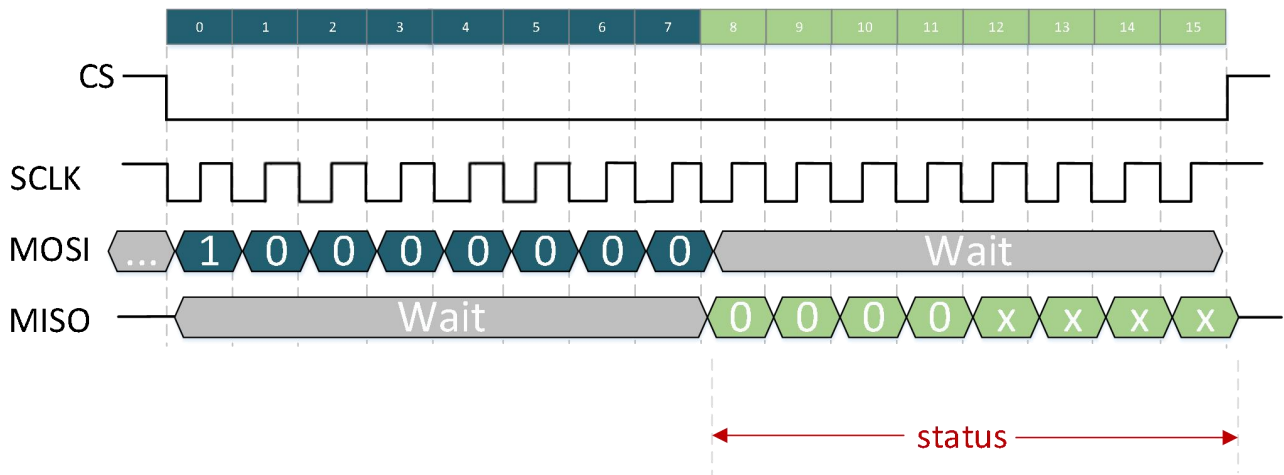

Figure 8-7. SPI Communication Diagram In Idle Mode

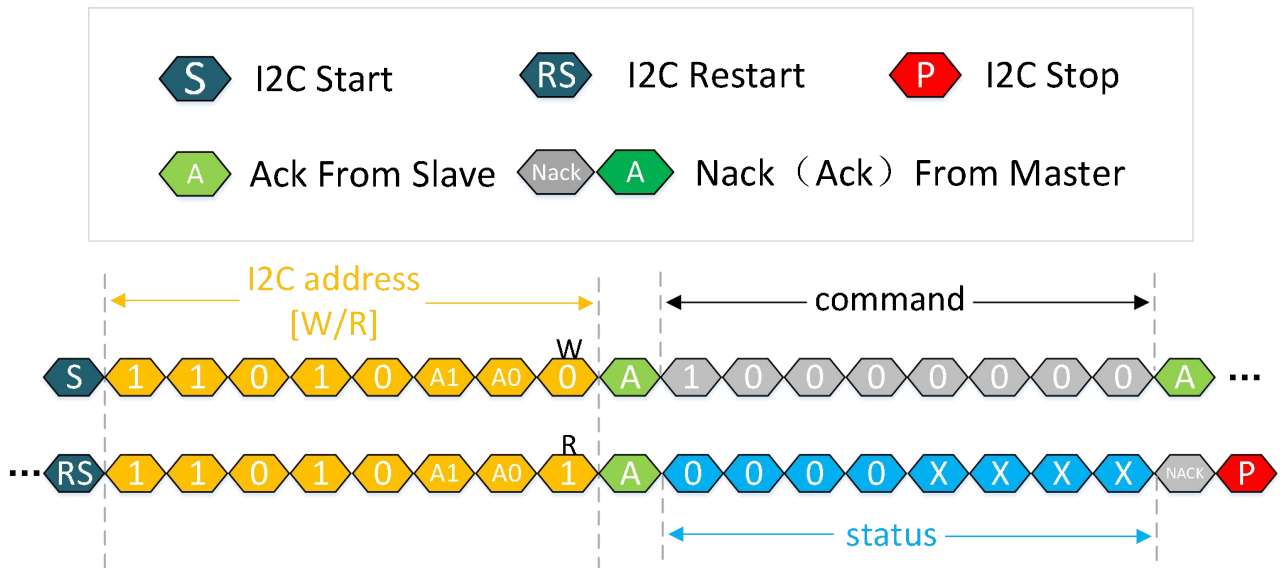

Figure 8-8. I2C Communication Diagram In Idle Mode

After the host sends an idle mode command to the chip, the chip will enter the idle state. When the chip is in Continuous Sensing mode or Wake-up & Sleep Mode, the chip cannot perform operations other than the measurement data readback frame, such as reading and writing registers. If you need to perform other operations on the chip, you need to send the idle mode command first to make the chip enter the idle state. However, after sending the idle mode command, the subsequent sent instructions cannot be executed immediately, and it is necessary to wait for the current measurement to be completed before entering the idle state from the Continuous Sensing Mode or Wake-up & Sleep Mode. And the chip needs to wait for the time to complete a measurement before it can perform other operations. The time to complete a measurement is related to the tempOsr, magnOsr, digCtrl, etc. configured in the chip. For the specific calculation method, see 6.5 Time Parameters.

Take the write register command as an example:

- Step 1: Send idle mode command
- Step 2: Wait for the time to complete a measurement

KTH5701 series

Low power, high accuracy 3D Hall sensor



Step 3: Send the write register command

Note: Idle state refers to the state that the chip is not in any measurement mode. The standby state refers to the state in which the chip is in the measurement mode and the measurement is intermittent.

9 Reset

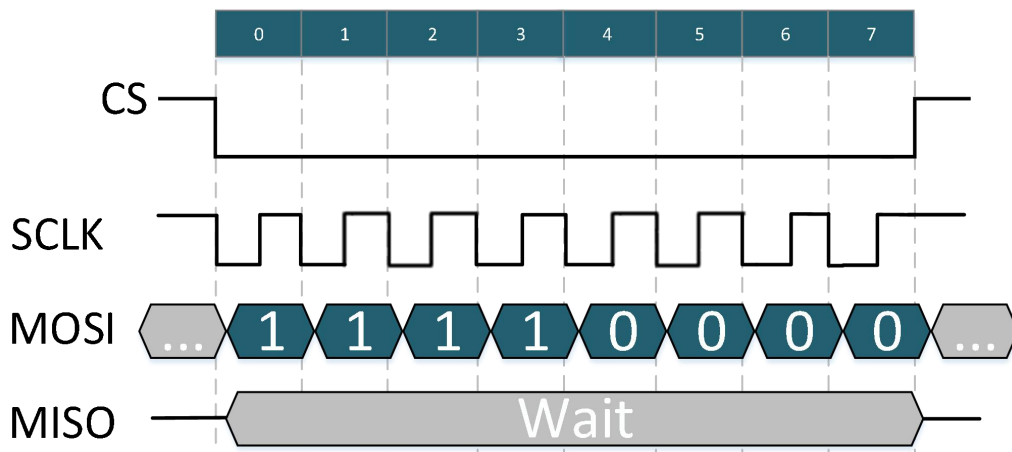

Figure 9-1. Reset SPI Communication Diagram

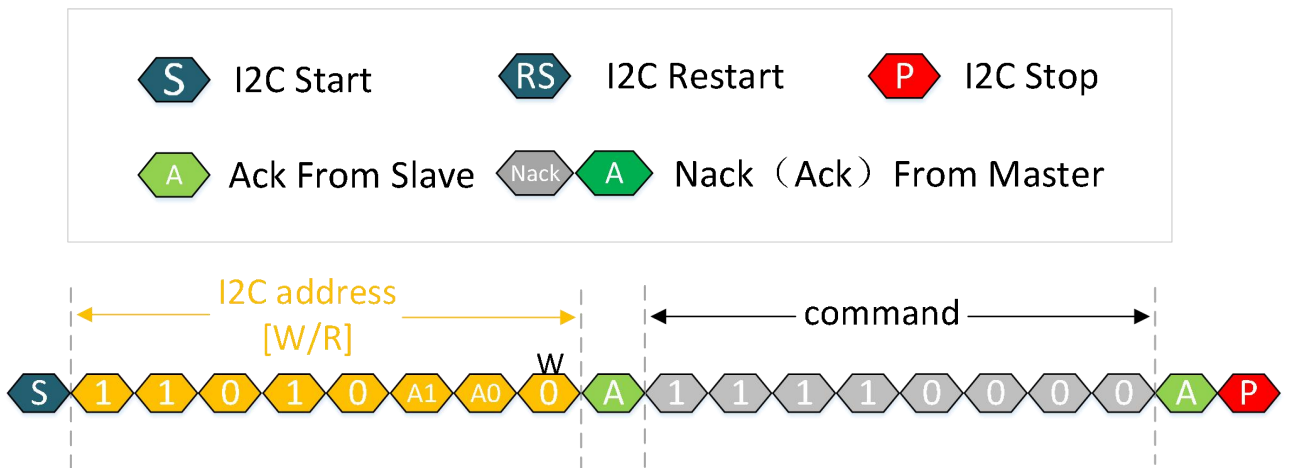

Figure 9-2. Reset I2C Communication Diagram

The internal register configuration is reset to the reset state.

If the chip is in continuous sensing mode or wake-up & Sleep mode, before resetting the chip, you need to send an idle mode command to make the chip return to the idle state.

10 Operating Status Description

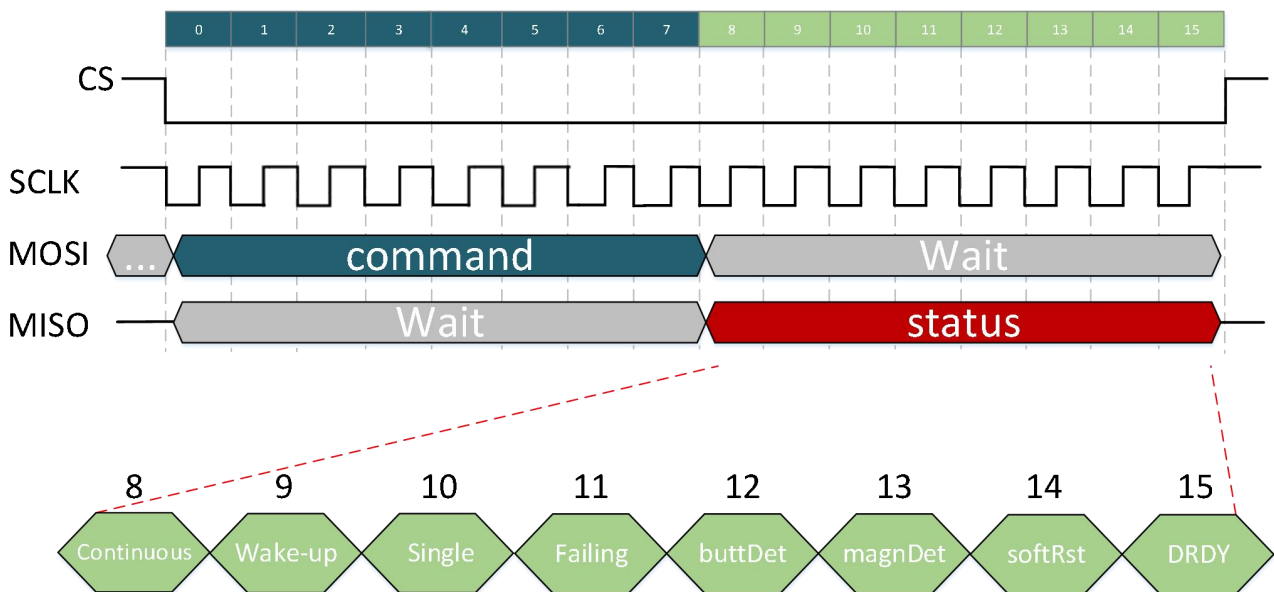
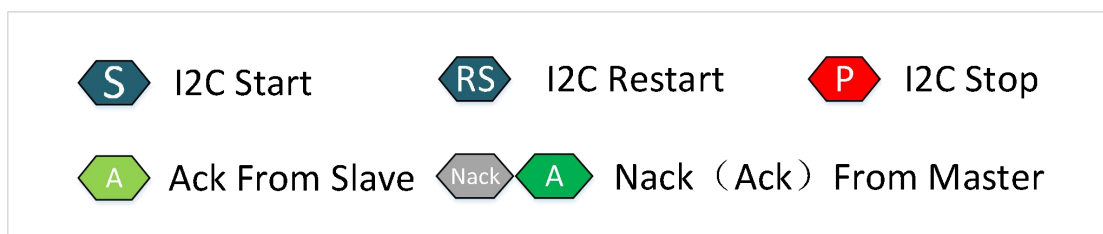

Figure 10-1. Operating Status SPI Description



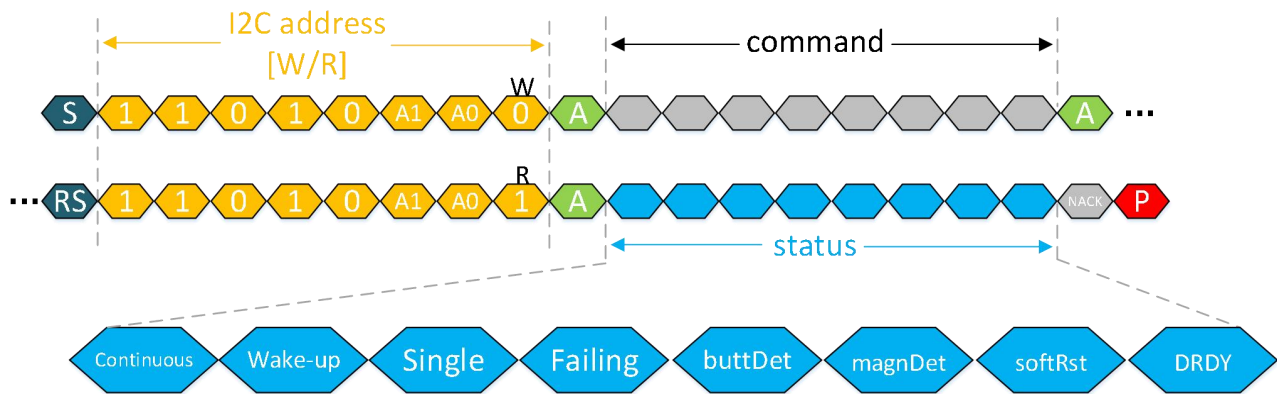

Figure 10-2. Operating Status I2C Description

In addition to resetting the chip, the chip will return to the operating state after other commands are sent;

- Continuous

When this bit is 1, it means that it is currently in continuous sensing mode. The host sends a continuous sensing mode command to the chip, and the bit in the returned status is set to 1, or when the chip is in continuous sensing mode, using the data Read Frame, the bit is also set to 1 when the measurement data is read back at one time.

- Wake-up

When the bit is 1, it means that it is currently in wake-up & Sleep mode. When the host sends a wake-up & Sleep mode command to the chip, the bit in the returned status is set to 1, or when the chip is in wake-up & Sleep mode, using the data Read Frame, this bit is also set to 1 when the measurement data is read back at one time.

- Single

When this bit is 1, it means that it is currently in single conversion mode. When the host sends a single conversion mode command to the chip, or the host sends a high-level pulse to the chip trig pin, the corresponding status returned by the command is then set to 1. After completing a single measurement, the chip returns to the idle state, such as sending other commands later, and the bit is 0 in the corresponding status returned.

- Failing

Failing = 1 when the currently sent command is invalid. When in any measurement state, send another measurement command again, the Failing bit will be set to 1. For example, when a single conversion command is sent while the continuous sensing mode is in progress, the Failing bit will be set to 1; At the same time, if the operation of the read and write registers is performed in continuous sensing mode, the Failing bit will also be set to 1, which represents a command error.

- buttDet

When buttDet = 1, it means that the chip detects the push button function;

In register configuration, when trigPushSel = 1, and the associated configuration register (address 0x1F) is configured, if the chip detects that the selected plane magnetic field value is greater than the configured value set in the register with address 0x1F, the returned status is set to 1, and the BUTT_OUT/TRIG pin is set to 1.

- magnDet

When magnDet = 1, it indicates that the magnetic field intensity currently detected by the chip is greater than the threshold magnetic field set in the register with address 0x1F;

KTH5701 series

Low power, high accuracy 3D Hall sensor



In the register configuration, when `absPushEn=0`, if the current magnetic field is greater than the value set by `pushConfig[15:13]` in the register whose address is `0x1F`, this bit in the returned status is set to 1.

- `softRst`

After the host sends a Reset command to the IC, the IC will not return status immediately. Therefore, it is necessary to judge whether the reset is successful according to the status returned when any command is received for the first time after the chip is reset. This bit is set to 1 after the chip is successfully reset, and is cleared to 0 after status is returned once, that is, when the chip receives any command for the second time after reset, the bit of status is 0.

- `DRDY`

When the host sends Continuous Sensing mode to the chip, the position is 1 after each measurement, and the bit is cleared after completing a data reading. When the host sends a Single Conversion Mode to the chip, the position 1 is completed after the measurement, and the bit is cleared to 0 after completing a data reading. When the host sends Wake-up & Sleep Mode to the chip, the corresponding magnetic field change detected by the chip exceeds the set threshold, the position 1, after completing a data reading, the bit is cleared to 0.

11 Data Read Frame

After the chip completes a measurement, use the data Read Frame to read back the chip operating status and all measurement data at one time. .

As shown in the figure below, after the host sends a data read back command to the chip, the chip will return the measurement values of all gated measurement items to the host at one time.

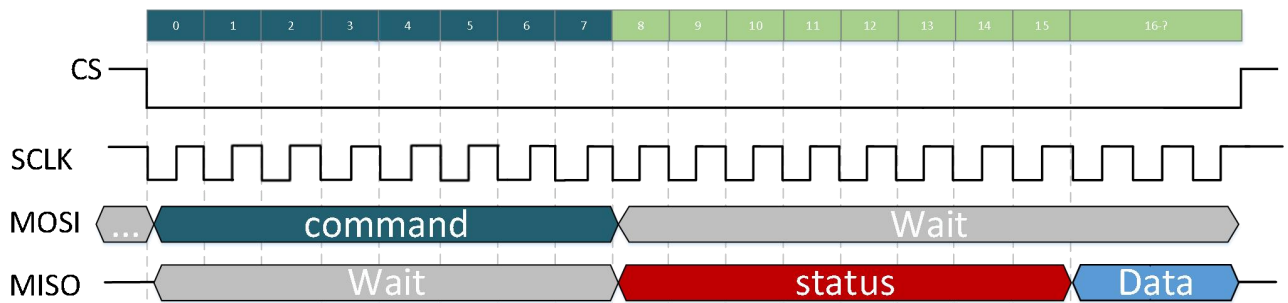

Figure 11-1. Data Read Frame SPI Communication Diagram

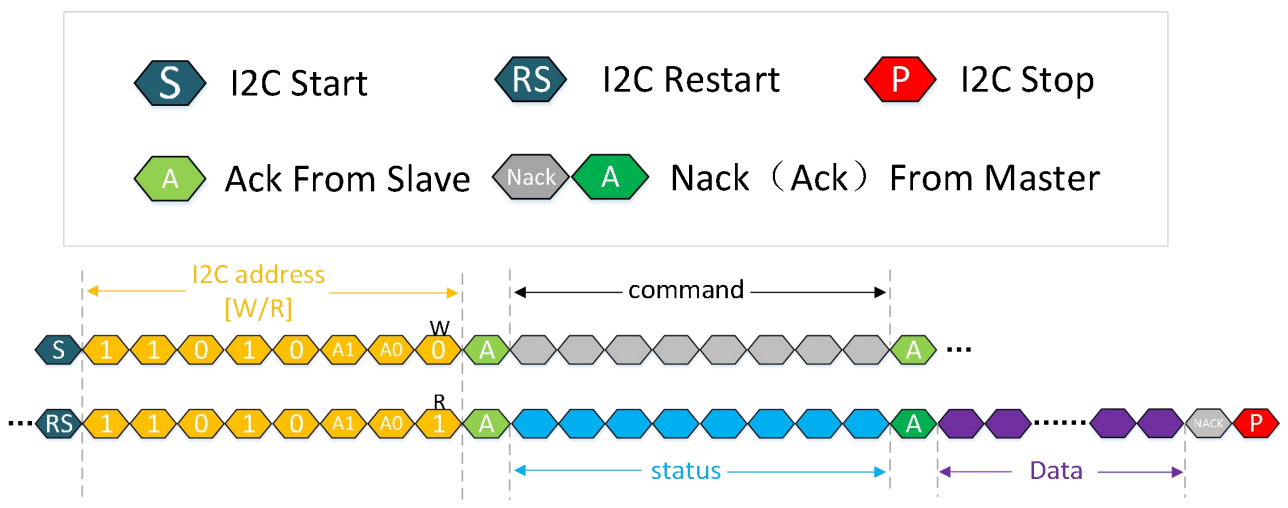

Figure 11-2. Data Read Frame I2C Communication Diagram

11.1 TXYZ Read Back Method

When `angMagnSel = 0` in the register, the host sends a one-time data read back command to the chip. You can choose to read back Z: Z-axis magnetic flux density, Y: Y-axis magnetic flux density, X: X-axis magnetic flux density, T: Current temperature. The return data of the magnetic field is a 16bit unsigned number. In an ideal situation, if there is no magnetic field around the chip, the output value of the three-axis magnetic field of the chip is 32768. The command sending part is shown in the figure below, and the complete communication format is shown in Figure 11-5 and Figure 11-6.

Taking the X-axis magnetic flux density as an example, the current X-axis magnetic flux density

$$B_x = \frac{X[15:8] \ll 8 + X[7:0] - 32768}{SENS_x}, \text{ unit: mT.}$$

Under the condition that it is not necessary to obtain the precise magnetic field value, it is usually use $X[15:8] \ll 8 + X[7:0] - 32768$ to represent the current X-axis magnetic flux density.

The calculated plus or minus sign, which represents the direction in which the current magnetic field is projected on that axis. The current magnetic field judgment method can be found in the magnetic field sensing direction of the chip. For example, the chip returns the parameter $X[15:8]=0x95$, $X[7:0]=0x32$, in the case of gaining set to 20 times,

$$B_x = \frac{0x9532 - 32768}{SENS_x} = \frac{38194 - 32768}{65.5} = 82.8, \text{ Unit: mT.}$$

Under conditions where it is not necessary to obtain the precise magnetic field value, it can use $0x9532 - 32768 = 5426$ to represent the current magnetic flux density.

Similarly, the calculation of the magnetic flux density of the other two axes can be obtained.

- Sensor output 32768 under non-magnetic conditions above, without considering Hall device and signal chain offsets, temperature drift and noise effects

KTH5701 series

Low power, high accuracy 3D Hall sensor

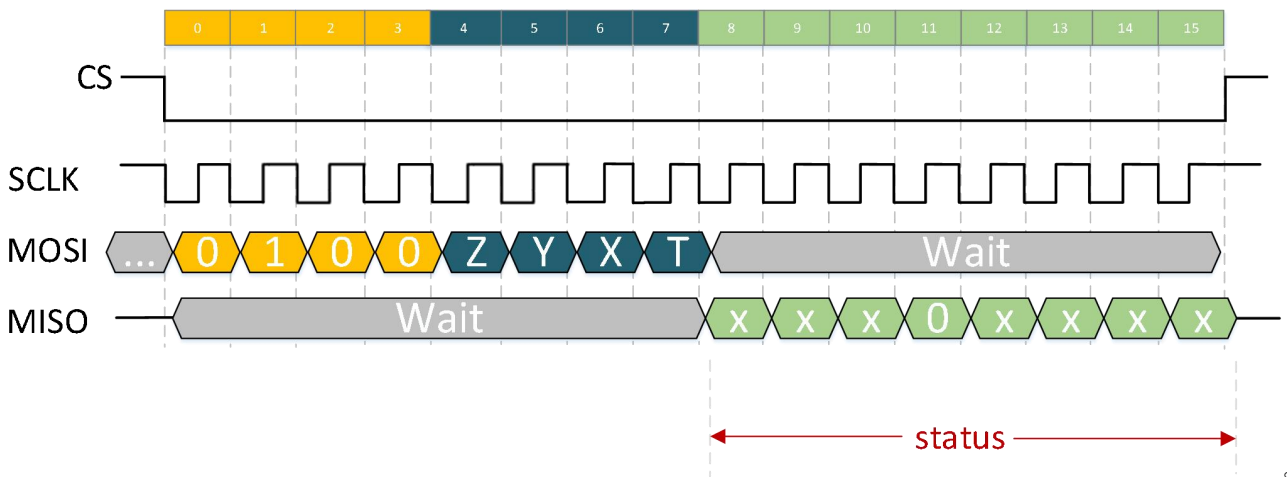

Figure 11-3. Data Read Frame TXYZ SPI Communication Diagram

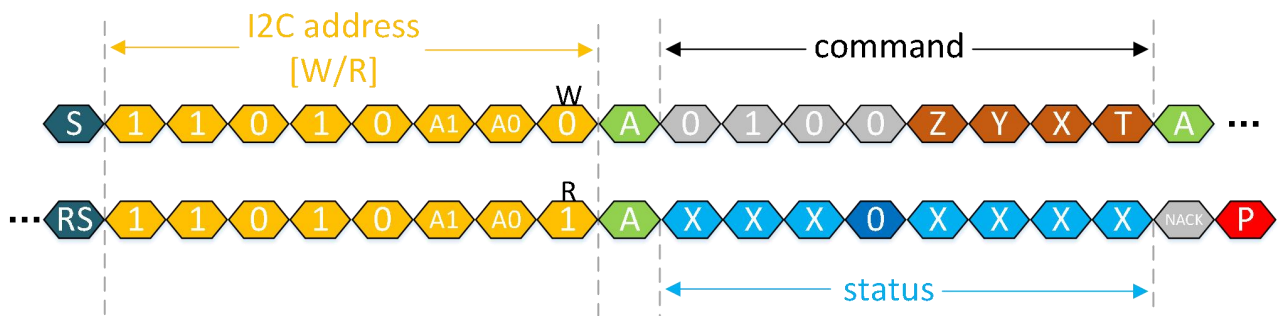

Figure 11-4. Data Read Frame TXYZ I2C Communication Diagram

The chip returns the data corresponding to the gating measurement value according to the gating of ZYXT. When all four ZYXT measurements are selected, data will be returned in the order of Status, T, X, Y, and Z. When only part of the measurements are selected, the unselected measurements will be skipped and no data will be returned. For example, TY is selected. Status, T, and Y are returned.

The following is an example diagram of command sending and data return when all four measurement data of ZYXT are gated.

KTH5701 series

Low power, high accuracy 3D Hall sensor

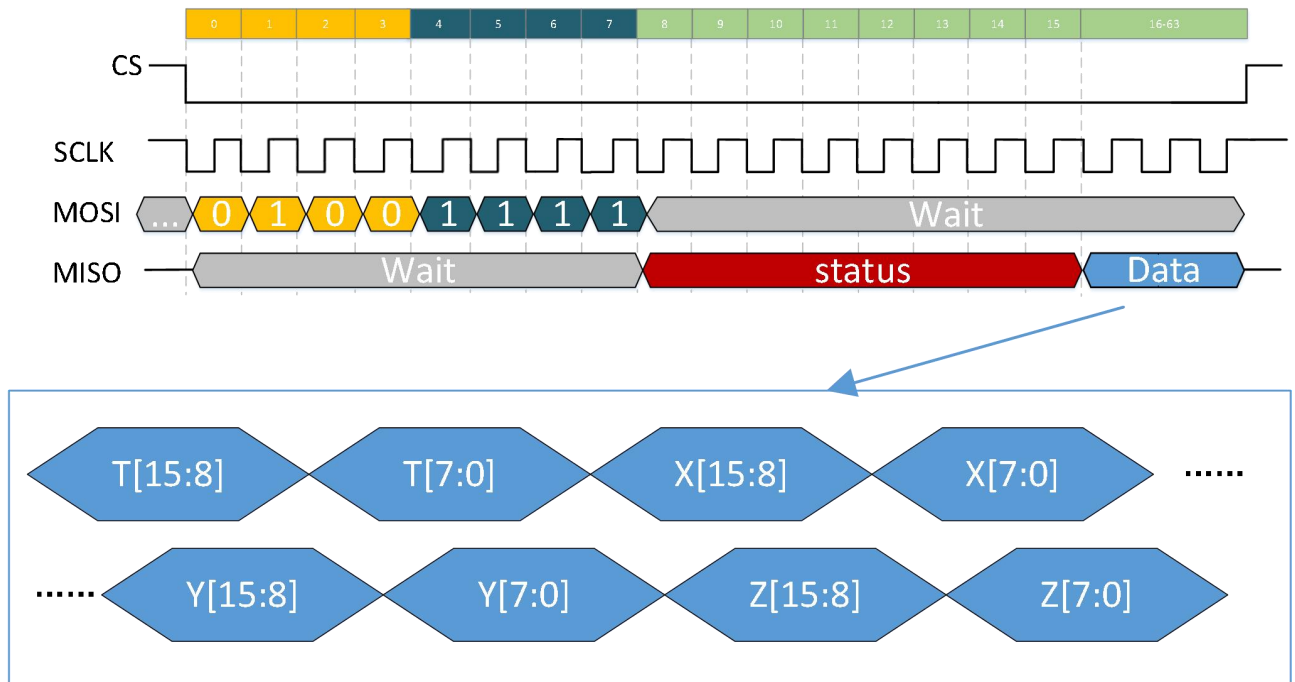

Figure 11-5. Data Read back In TXYZ SPI Communication Diagram

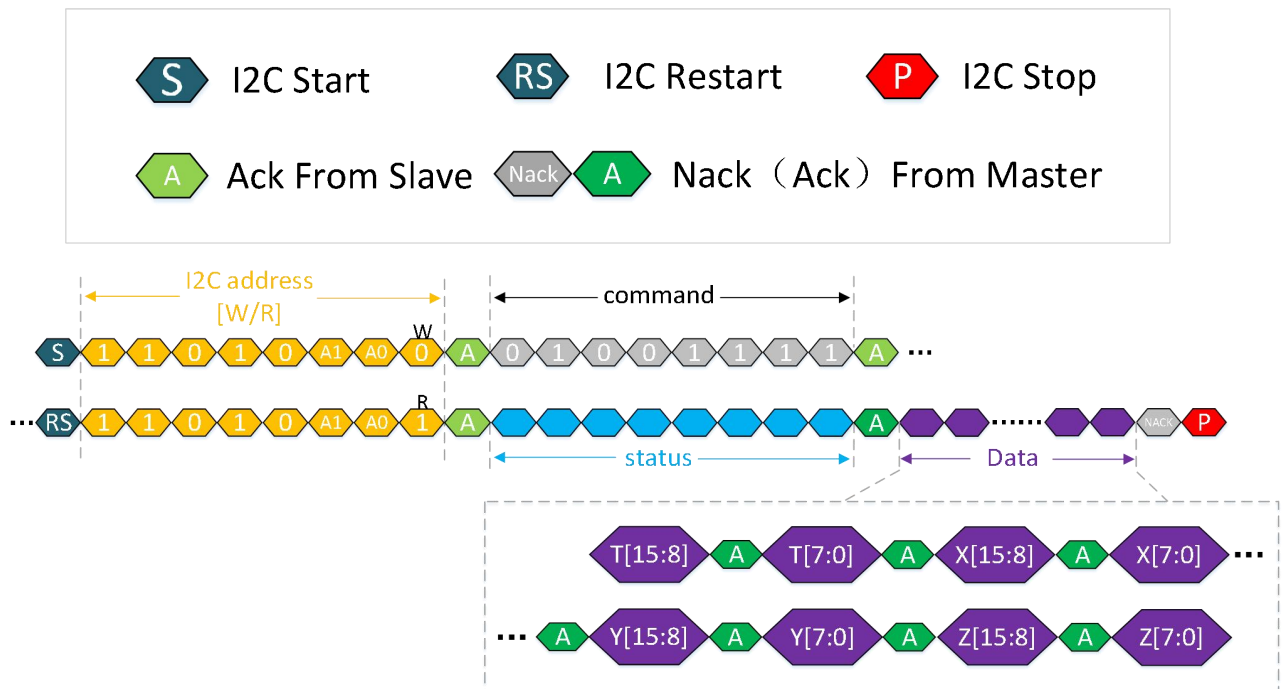

Figure 11-6. Data Read back In TXYZ I2C Communication Diagram

The following figure is an example diagram of command sending and data return when only YT is enabled

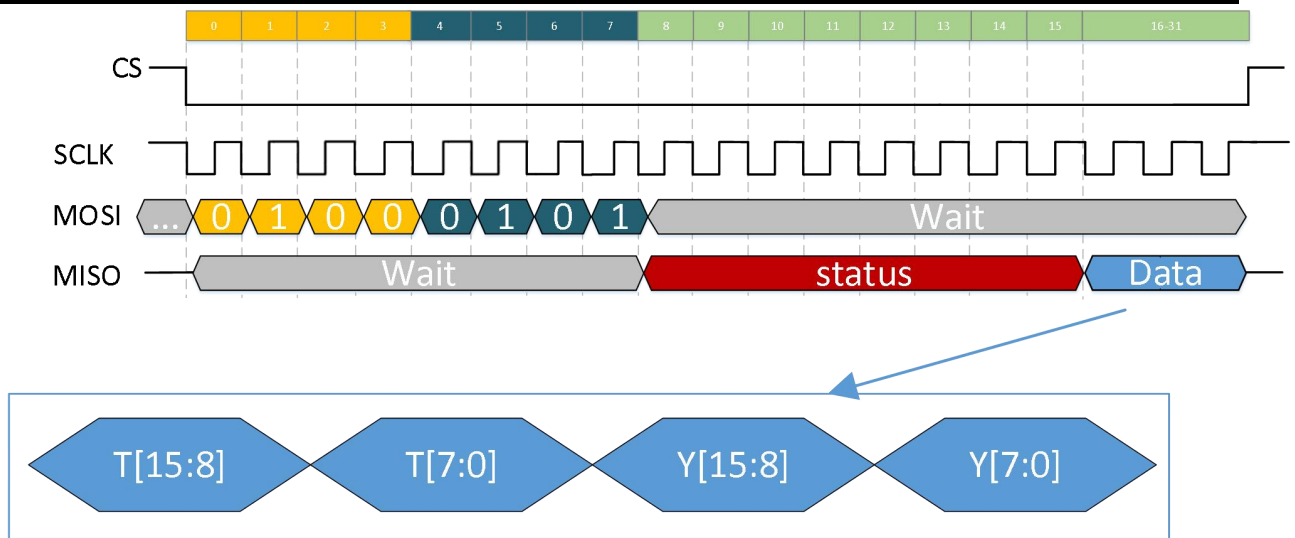

Figure 11-7. Data Read Back In YT SPI Communication Diagram

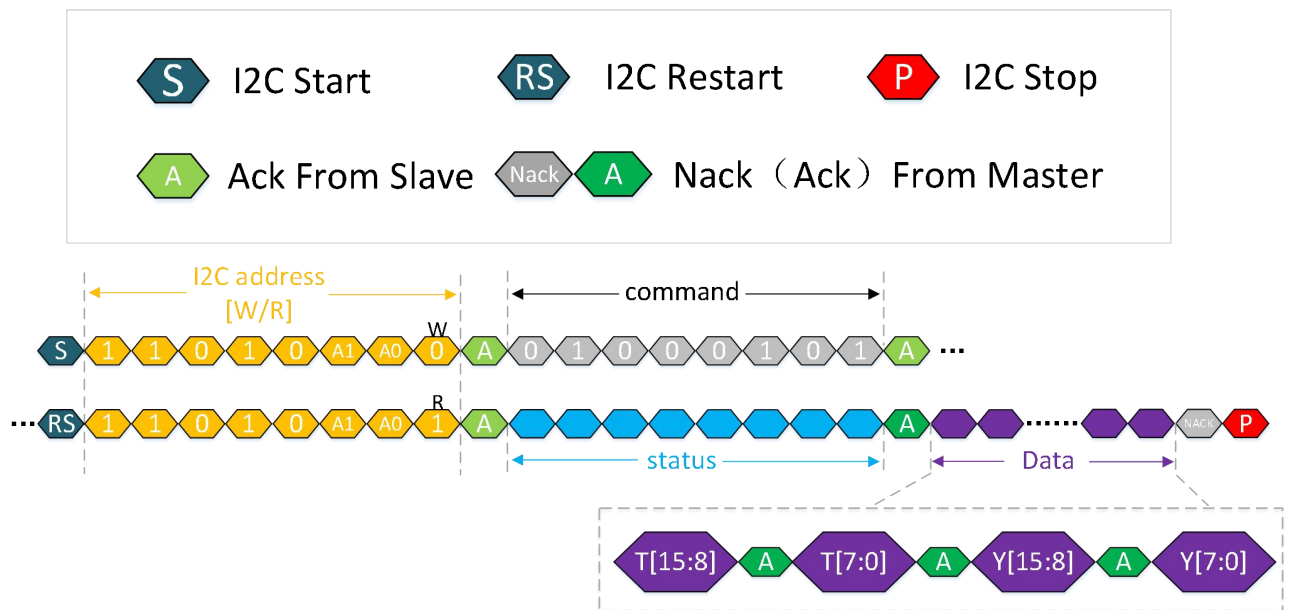

Figure 11-8. YT Data Read Back I2C Communication Diagram

11.2 TABZ Read Back Method

When `angMagnSel = 1` in the register, the host sends a one-time data read back command to the chip, and you can choose to read back Z: Z-axis magnetic flux density, B: The corresponding amount of the plane magnetic field calculated from the two axes of the selected plane by the CORDIC algorithm, A: Plane angle, T: Current temperature.

By modifying the `AplaneSel` bit in the `0x1C` register, the output planes of B and T A can be changed, but Z, T will not

KTH5701 series

Low power, high accuracy 3D Hall sensor



change. For example, when AplaneSel=1, B is the corresponding value of the YZ plane magnetic field calculated by the CORDIC algorithm from the magnetic flux density of the Y axis and the Z axis, and A is the angle between the YZ plane. While Z is still the magnetic flux density of the Z axis, T is the current temperature.

The sending part is shown in the figure below, and the complete communication format is shown in Figure 11-11 and Figure 11-12.

Returns the 16bit angle value, the angle corresponding to each LSB is $\frac{360^\circ}{2^{16}}$ for example, return A[15:8]=0x90 ,

A[7:0]=0x30, then A[15:0]=0x9030 , The angle of the magnetic field in the selected plane= $A[15:0] * \frac{360^\circ}{2^{16}}$

= $0x9030 * \frac{360^\circ}{2^{16}}$. Since the magnetic field value is calculated by the CORDIC algorithm, the value corresponding to

the actual magnetic flux density should be $\frac{B[15:0] * 0.60725}{Sensitivity}$.

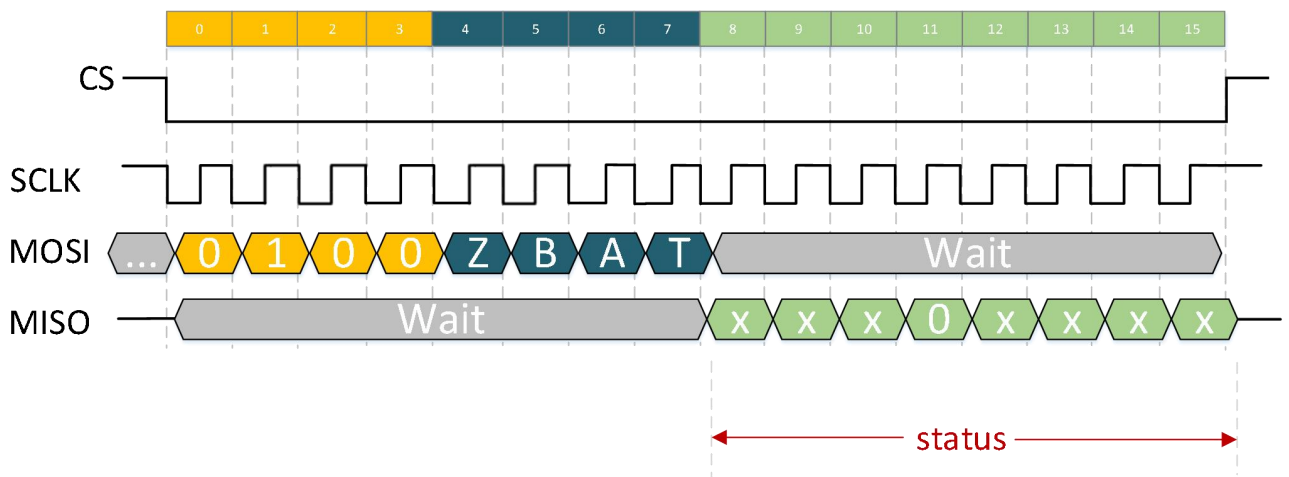

Figure 11-9. TABZ Data Read Back SPI Communication Diagram



KTH5701 series

Low power, high accuracy 3D Hall sensor

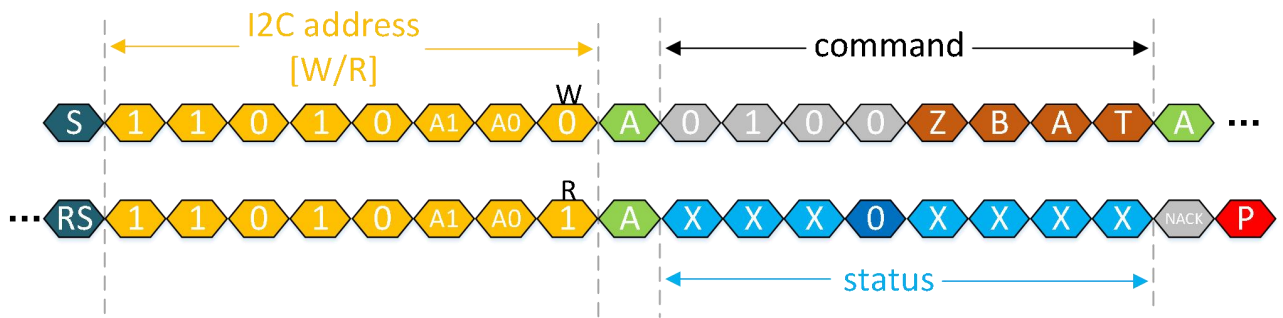

Figure 11-10. TABZ Data Read Back I2C Communication Diagram

The chip returns the data corresponding to the gating measurement value according to the gating of ZBAT. When all four measurement data of ZBAT are gating, all data are returned in the order of Status, T, A, B, and Z. When only some of the measurements are selected, the part that is not selected will be skipped and no data will be returned. If BT is selected, it will be returned according to Status, T, and B.

The following figure is an example diagram of command sending and data return when all four measurement data of ZBAT are gated.

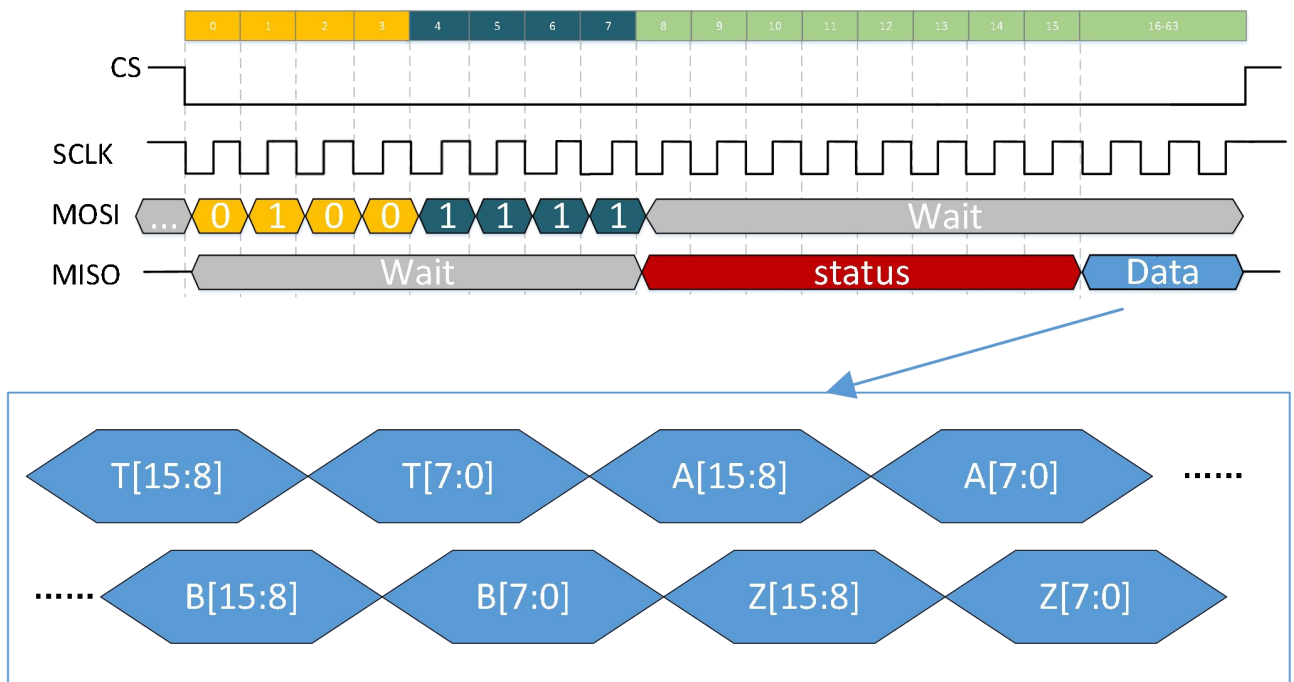

Figure 11-11. TABZ Data Read Back SPI Communication Diagram

KTH5701 series

Low power, high accuracy 3D Hall sensor

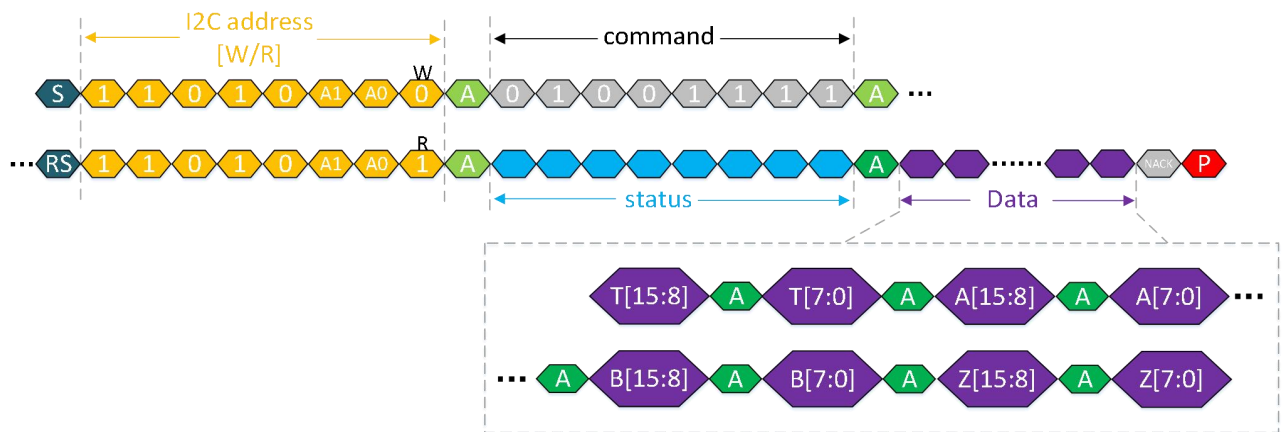

Figure 11-12. TABZ Data Read Back I2C Communication Diagram

The following figure is an example diagram of command sending and data return when only BT is enabled.

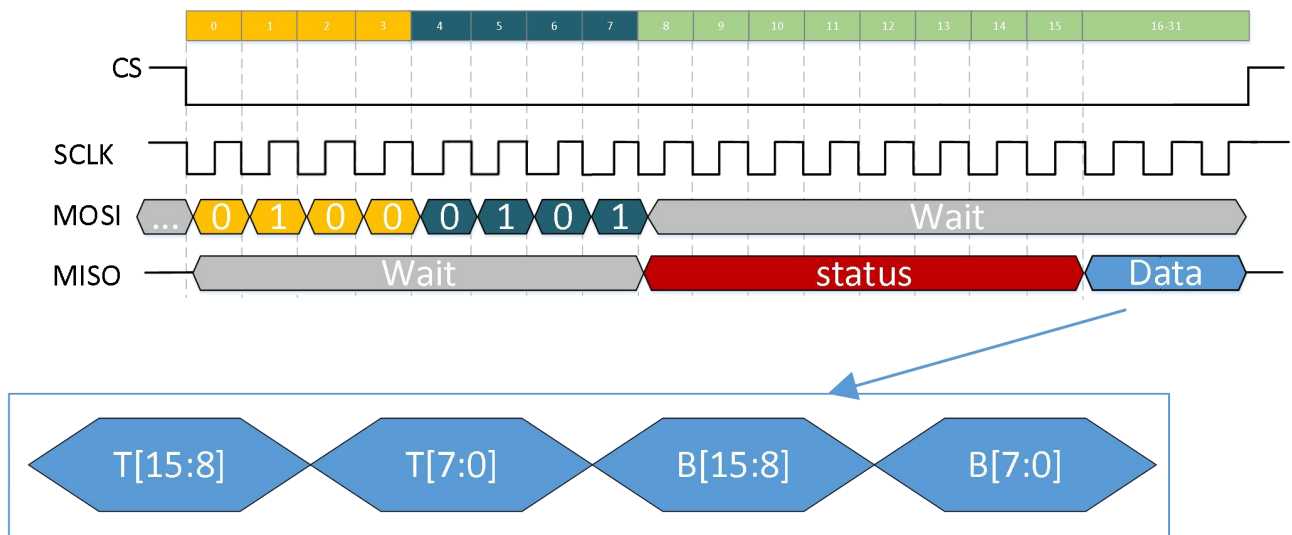

Figure 11-13. TB Data Read Back SPI Communication Diagram

KTH5701 series

Low power, high accuracy 3D Hall sensor

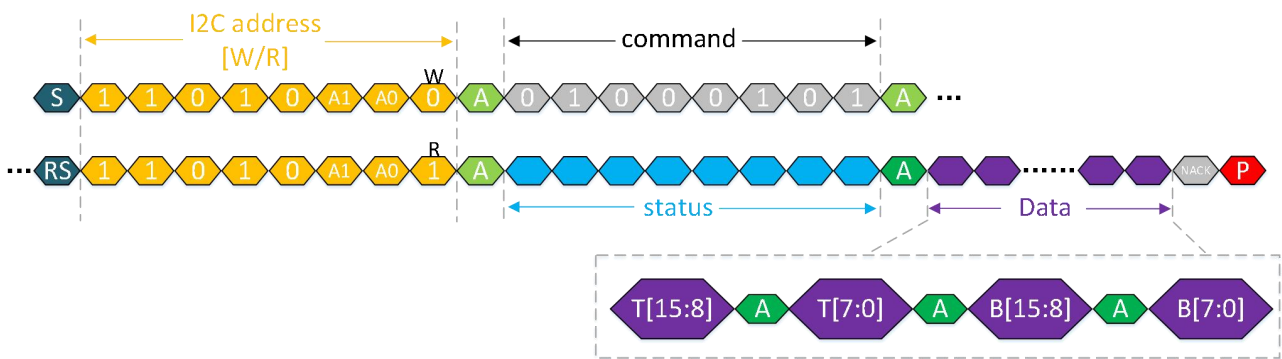
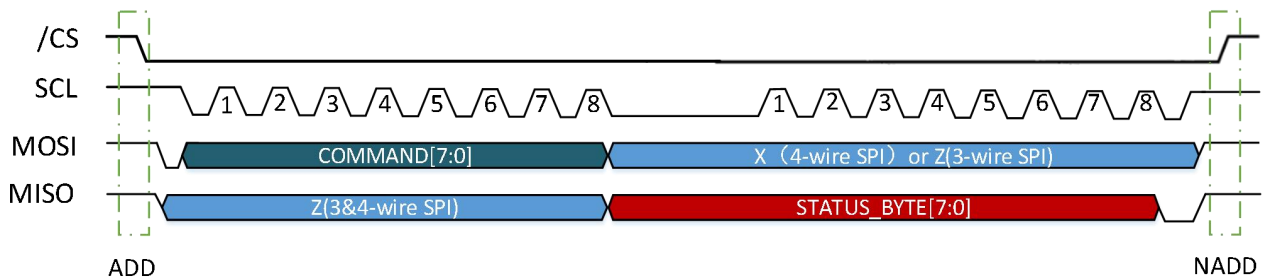

Figure 11-14. TB Data Read Back I2C Communication Diagram

12 SPI Communication Mode

Note: The following parameters are measured at room temperature 25° C, Vdd = 3.3V.

The design adopts SPI mode 3: CPHA=1 (data is changed on the first edge, and the second edge is sampled and acquired), CPOL=1 (high level is inactive state).



Electrical Parameters	Symbol	Min.	Max.	Unit
SPI Clock Cycle	$t_c(\text{SPC})$	200		ns
SPI Clock Cycle	$t_c(\text{SPC})$		5	MHz
CS Setup Time	$t_{su}(\text{CS})$	5		ns
CS Hold Time	$t_h(\text{CS})$	10		ns
SDI Input Setup Time	$t_{su}(\text{SI})$	5		ns
SDI Input Hold Time	$t_h(\text{SI})$	15		ns
SDO Valid Output Time	$t_v(\text{SO})$		50	ns
SDO Output Hold Time	$t_h(\text{SO})$	5		ns

KTH5701 series

Low power, high accuracy 3D Hall sensor



SDO Output Disable Time	$t_{dis}(SO)$	50	ns
-------------------------	---------------	----	----

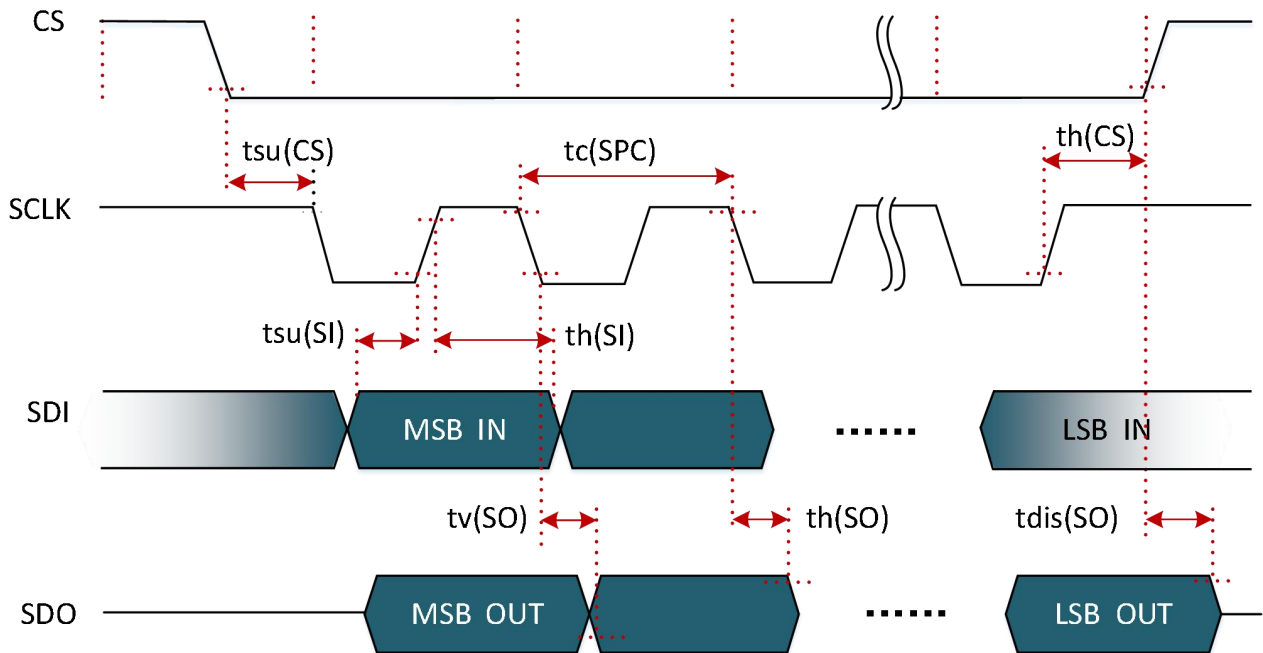

Figure 12-1 SPI Timing Diagram

13 I2C Communication Mode

Note: The following parameters are measured at room temperature 25° C, Vdd = 3.3V.

Electrical Parameters	Symbol	Standard Mode		Fast Mode		Unit
		Min.	Max.	Min.	Max.	
SCL Clock Frequency	f (SCL)		100		400	kHz
SCL Clock Low Time	tw (SCLL)	4.7		1.3		μ s
SCL Clock High Time	tw (SCLH)	4		0.6		μ s
SDA Setup Time	tsu (SDA)	250		100		ns
SDA Data Hold Time	th (SDA)		3.45		0.9	μ s
SDA and SCL Rise Time	tr (SDA) tr (SCL)		1000		300	ns
SDA and SCL Fall Time	tf (SDA) tf (SCL)		300		300	ns
START Condition Hold Time	th (ST)	4		0.6		μ s
REPEATED START Condition Setup Time	tsu (SR)	4.7		0.6		μ s
STOP Condition Setup Time	tsu (SP)	4		0.6		μ s
Bus Free Time Between STOP and START	tw(SP:ST)	4.7		1.3		μ s

KTH5701 series

Low power, high accuracy 3D Hall sensor



Condition							
-----------	--	--	--	--	--	--	--

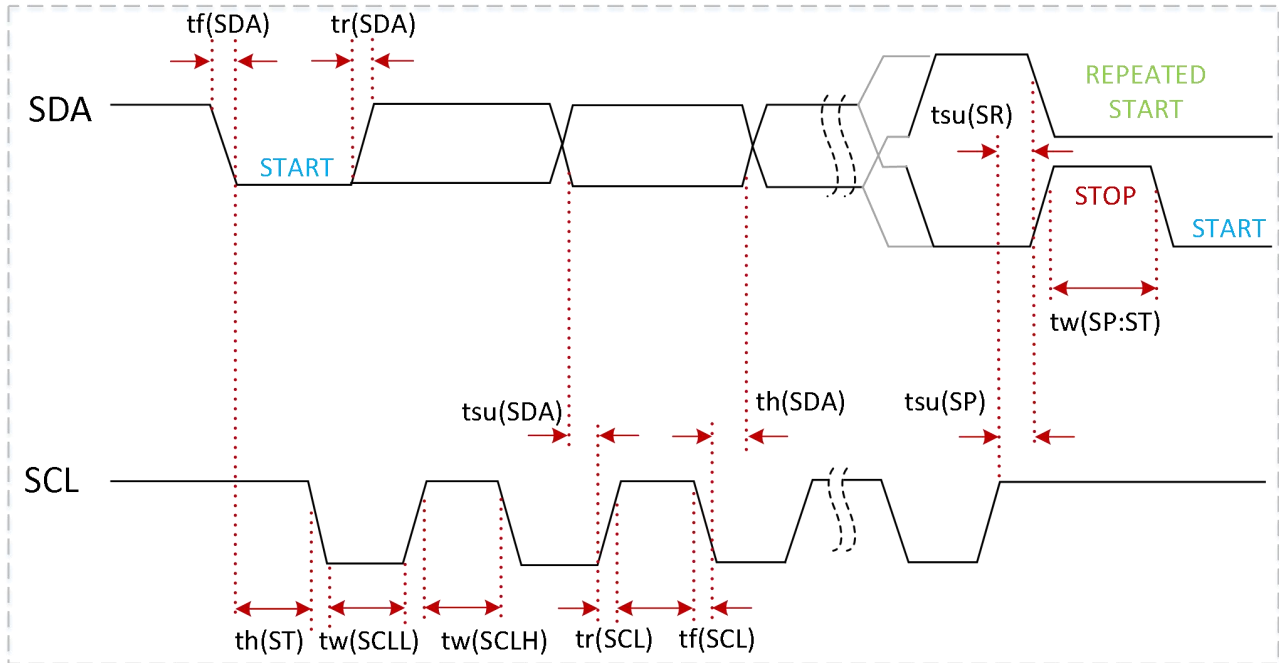

Figure 13-1 I2C Timing Diagram

14 Special Pin Description

INT: The host sends a Continuous sensing mode or a single conversion command to the chip. After the chip completes a measurement of the corresponding measurement item, the INT pin will be set to 1, and it will remain 1 until the chip sends a read command and reads back the measurement data. After the host sends the wake-up & Sleep mode command to the chip, when the change of the measurement items around the chip exceeds the change threshold set in the register, the INT pin will be set to 1, and it will remain 1 until the chip sends a read command and reads back the measurement data .

BUTT_OUT/TRIG: When the host configures this pin as push button output pin ($trigPushSel=1$), if the chip detects an increase in the magnetic field of the selected plane and exceeds the set threshold, the BUTT_OUT/TRIG pin is placed 1. It should be noted that this function detects the magnetic field of the selected plane, that is, when sending the measurement command, it is necessary to gating the selected plane corresponding to two axes at the same time. That is, to detect changes in magnetic flux density in the XY plane, it is necessary to gated the measurement of magnetic flux density in both the X and Y axes. When the host configures this pin as a single conversion mode trigger pin ($extTrig=1$, $trigPushSel=0$), if the host sends a high pulse to the BUTT_OUT/TRIG pin, the chip makes a single measurement. When the BUTT_OUT-low TRIG pin is configured as a trigger pin, the pin must not be floating and needs to remain low after the external triggering is complete.

15 Read and Write Register Description

After the chip is powered on, internal initialization is performed. When the power supply is stable, the value of OTP is read into the corresponding register. The reading of OTP is completed within 4ms after power-on, and communication is not allowed within 4ms after power-on. After the initialization is completed The chip enters an idle state, allowing communication measurements.

When reading and writing a register, the register address should be shifted left by two bits, as shown in the figure.

15.1 SPI Communication

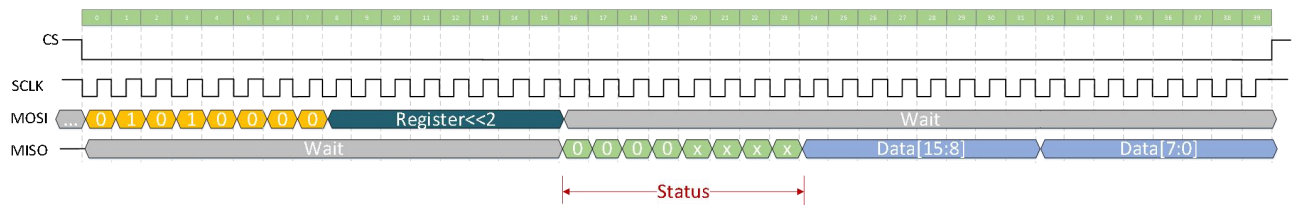

Figure 15-1. Read Register SPI Timing Diagram

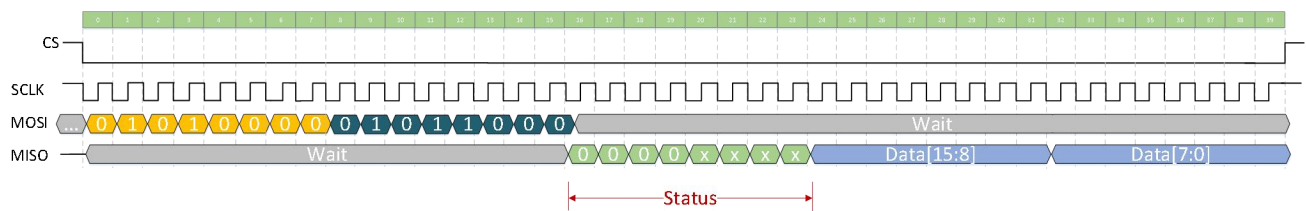

Figure 15-2. Read Register 0x16 SPI Timing Diagram

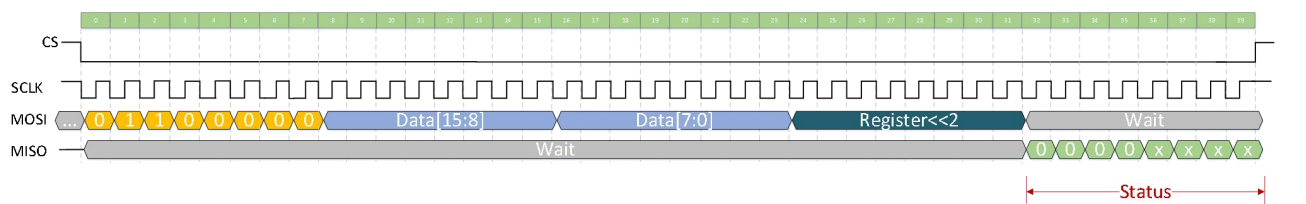

Figure 15-3. Write Register SPI Timing Diagram

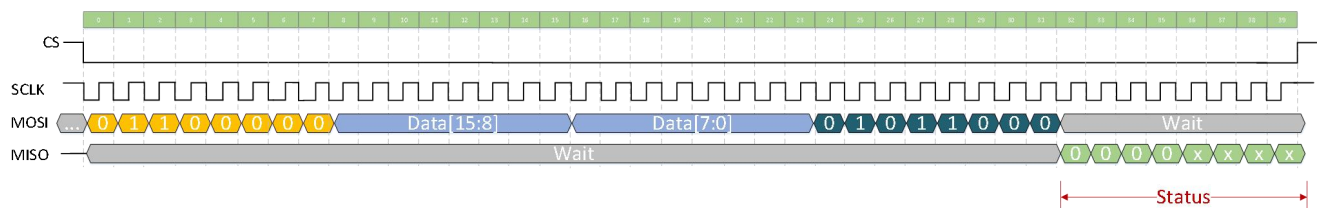

Figure 15-4. Write Register 0x16 SPI Timing Diagram

15.2 I2C Communication

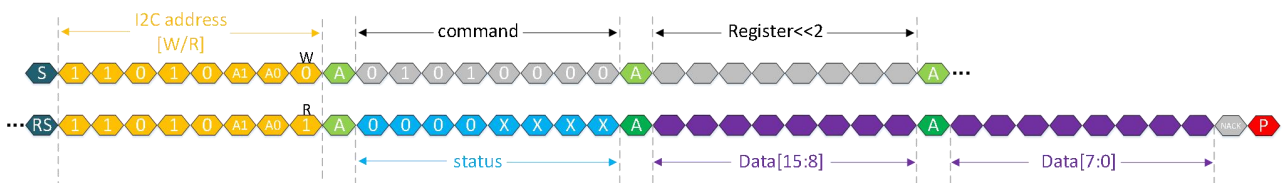
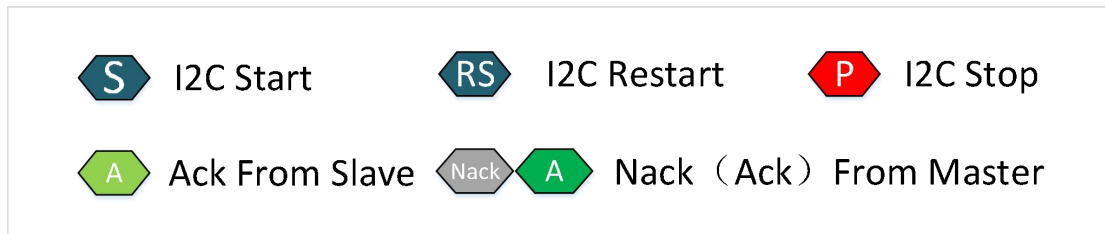

Figure 15-5. Read Register I2C Timing Diagram

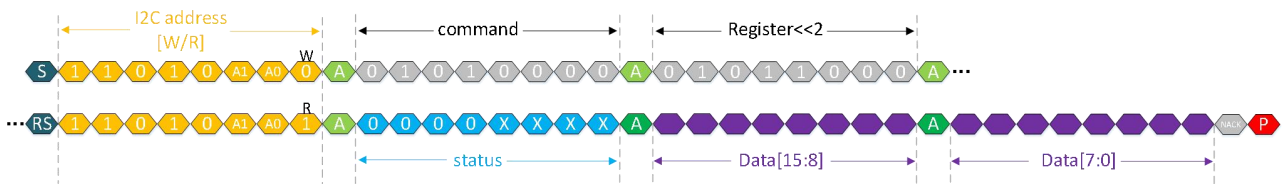

Figure 15-6. Read Register 0x16 I2C Timing Diagram

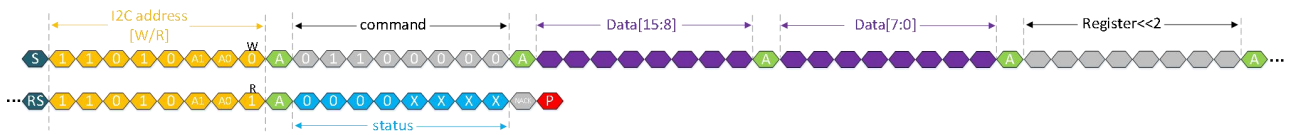

Figure 15-7. Write Register I2C Timing Diagram

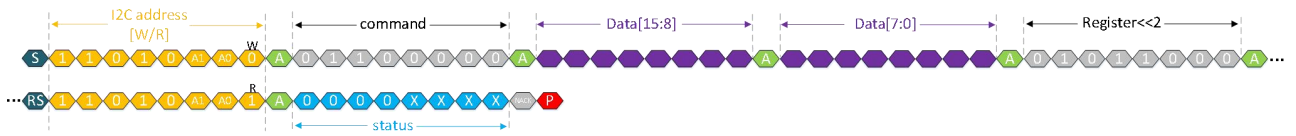

Figure 15-8. Write Register 0x16 I2C Timing Diagram

KTH5701 series

Low power, high accuracy 3D Hall sensor



16 Register Map Description

The OTP can be programmed from registers 0x14 to 0x1F.

KTH5701 series

Low power, high accuracy 3D Hall sensor



	15	14	13	12	11	10	9	8	7	6	5	4	3	2	1	0
0x06									Continuous	Wake-up	Single	Failing	buttDet	magnDet	softRst	DRDY
0x07																read_otp
0x08																Program_otp
0x09									ls_en	rd[1:0]				wse[3:0]		
0x0A														add[5:0]		
0x0B									otp_din[15:0]							
0x0D									chip_id[15:0]							
...																
0x14									offsetX[15:0]							
0x15									offsetY[15:0]							
0x16									offsetZ[15:0]							
0x17								sensxyHt[7:0]				sensxyLt[7:0]				
0x18								senszHt[7:0]				senszLt[7:0]				
0x19								wxyTh[15:0]								
0x1A								wzTh[15:0]								
0x1B		gainSel	gainValue[13:0]													
0x1C		AplaneSel	wakeSel	tempOsr	magnOsr	trigPushSel	ext Trig		gain							digCtrl
0x1D		xPol	yPol	zPol	absPushEn	wakeDiff	tcmpEn		measSel							measTime
0x1E		ang MagnSel	zero[15:1]													
0x1F		pushConfig														

Colour legend for the Bitmap

	Status		Wake Up Sleep Mode		Pushbutton Function		Amplitude Adjustment		Magnetic field angle output switching
--	--------	--	--------------------	--	---------------------	--	----------------------	--	---------------------------------------

0x06

15	14	13	12	11	10	9	8	7	6	5	4	3	2	1	0
								Continuous	Wake-up	Single	Failing	buttDet	magnDet	softRst	DRDY

Status register, when the host sends a command to KTH5701 according to the communication protocol, if the sent command requires KTH5701 to answer, the chip will return the current chip status in the first byte, and this status value corresponds to the flag bits stored in the 0x06 register.

Field	Bit	R/W	Description
-------	-----	-----	-------------

KTH5701 series

Low power, high accuracy 3D Hall sensor



DRDY	0	R	When the host sends Continuous Sensing mode to the chip, the bit is set to 1 after each measurement, and the bit is cleared 0 after completing a data reading. When the host sends a single conversion mode to the chip, the bit is set to 1 after the measurement is completed, and the bit is cleared to 0 after completing a data reading. When the host sends Wake-up & Sleep Mode to the chip, when the corresponding magnetic field change detected by the chip exceeds the set threshold, the bit is set to 1, and the bit clears 0 after completing a data reading.
softRst	1	R	After the host sends a reset command to the IC, the IC will not return status immediately. Therefore, it is necessary to judge whether the reset is successful according to the status returned when any command is received for the first time after the chip is reset. This bit is set to 1 after the chip is successfully reset, and is cleared to 0 after status is returned once, that is, when the chip receives any command for the second time after reset, the bit of status is 0.
magnDet	2	R	When magnDet = 1, it indicates that the magnetic field intensity currently detected by the chip is greater than the threshold magnetic field set in the register with address 0x1F. In the register configuration, when absPushEn=0, if the current magnetic field is greater than the value set by pushConfig [15:13] in the register whose address is 0x1F, this bit in the returned status is set to 1.
buttDet	3	R	When buttDet = 1, it means that the chip detects the button function. In the register configuration, when trigPushSel = 1, the button function is enabled, and after configuring the related configuration register (register with address 0x1F), If the chip detects that the selected plane magnetic field value is greater than the value set in the register with the address 0x1F, the returned status is set to 1 and the BUTT_OUT/TRIG pin is set to 1.
Failing	4	R	Failing =1 when the currently sent command is invalid. When in any measurement state, send another measurement command again, the Failing bit will be set to 1. For example, when a single conversion command is sent while the continuous sensing mode is in progress, the Failing bit will be set to 1; At the same time, if the operation of the read and write registers is performed in continuous sensing mode, the Failing bit will also be set to 1, which represents a command error.
Single	5	R	After the host sends a single conversion command (0x3x) to the chip, or sends a high-level pulse to the chip trig pin, the chip enters the single conversion mode, and the bit is set to 1.
Wake-up	6	R	After the host sends the wake-up & Sleep mode command (0x2x) to the chip, the chip enters the wake-up measurement mode, and this bit is set to 1.
Continuous	7	R	After the host sends the continuous sensing mode command (0x1x) to the chip, the chip enters the continuous sensing mode, and this bit is set to 1.

0x0A

15	14	13	12	11	10	9	8	7	6	5	4	3	2	1	0
----	----	----	----	----	----	---	---	---	---	---	---	---	---	---	---

KTH5701 series

Low power, high accuracy 3D Hall sensor



senszHt	senszLt
---------	---------

Field	Bit	R/W	Description
senszLt	7:0	RW	When the temperature is lower than Tref, the sensitivity calibration parameter of the Z axis.
senszHt	15:8	RW	When the temperature is higher than Tref, the sensitivity calibration parameter of the Z axis.

Note: Tref is the temperature value of the temperature sensor at the reference temperature point.

0x19:

15	14	13	12	11	10	9	8	7	6	5	4	3	2	1	0
----	----	----	----	----	----	---	---	---	---	---	---	---	---	---	---

wxyTh

Field	Bit	R/W	Description
wxyTh	15:0	RW	<p>Wake-up magnetic flux density threshold for the XY axis when the chip is configured for magnetic flux density output (TXYZ output).</p> <p>When the host sends a wake-up & Sleep mode command to the chip, if any XY axis is gated, when the chip detects that the magnetic field change value of this axis exceeds the threshold set in wxyTh, the INT pin will be pulled high. If the XY two-axis measurement is enabled at the same time, when the chip detects the magnetic field change value of any one of the axes and exceeds the threshold set in wxyTh, the INT pin will be pulled high.</p> <p>Note: The magnetic field change value is the difference between the current magnetic field value and the reference value. The setting of the reference value is related to wakeSel in reg 0x1C and wakeDiff configuration in reg 0x1D. Please refer to the corresponding reg description for details.</p> <p>When the host controls the angMagnSel register to make the chip in the angle output state, the wake-up & Sleep mode no longer has three selection modes, only the reference value does not update the mode, and wxyTh no longer stores the xy magnetic field threshold, but the storage expects to reach the wake-up angle threshold.</p> <p>When the chip is configured as angle output (TABZ), it is the wake-up threshold of the XY plane angle, and the trigger condition has nothing to do with the configuration of wakeSel and wakeDiff. As long as the XY plane angle detected by the chip is greater than the angle configured in wxyTh,</p>

KTH5701 series

Low power, high accuracy 3D Hall sensor



			<p>the INT pin is pulled high, the calculation of the write angle in wxyTh is consistent with the calculation method when reading the chip angle output.</p> <p>For example, when the chip detects that the angle between the XY plane is greater than 45°, the INT pin is pulled high, and the corresponding hexadecimal number $\frac{45^\circ * 2^{16}}{360^\circ}$ is written in wxyTh, that is, 0x2000.</p> <p>Regardless of whether the external magnetic field changes, as long as the angle between the XY planes currently detected by the chip is greater than 45°, the INT pin will be pulled high.</p>
--	--	--	---

0x1A:

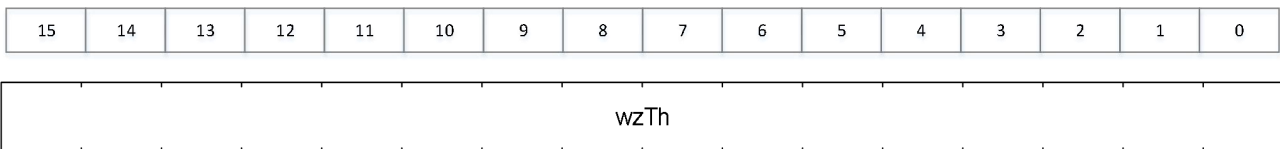

Field	Bit	R/W	Description
wzTh	15:0	RW	<p>Z-axis wake-up magnetic flux density threshold; unsigned</p> <p>When the host sends a wake-up & Sleep mode command to the chip, if the Z-axis is turned on, when the chip detects that the magnetic field change value of the Z-axis exceeds the threshold set in wzTh, the INT pin will be pulled high.</p> <p>Note: The magnetic field change value is the difference between the current magnetic field value and the reference value. The setting of the reference value is related to wakeSel in reg 0x1C and wakeDiff configuration in reg 0x1D. Please refer to the corresponding reg description for details.</p>

0x1B:

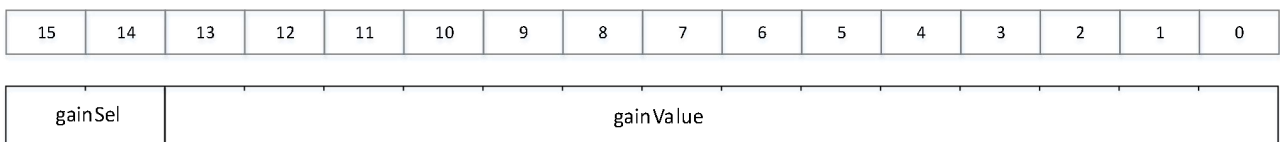

Field	Bit	R/W	Description
gainValue	13:0	RW	In the Rotary Application, the two-axis magnetic field used to calculate

			<p>the corresponding plane angle may have different amplitudes of the two-axis magnetic field due to assembly tolerances or off-axis applications. gainValue applies an amplitude adjustment to the axis selected in gainSel.</p> <p>gainValue = k*8192</p> <p>k is the magnitude ratio of the two axes currently used to calculate the plane angle.</p> <p>For example:</p> <ul style="list-style-type: none"> • It is necessary to obtain the YZ plane angle. There are various problems such as different YZ axis measurement sensitivity and assembly tolerance, resulting in different YZ two-axis magnetic field amplitudes. • If you want to perform amplitude adjustment on the Z axis, so that the YZ amplitude is the same when the knob is rotated once, set gainSel to 3 <p>Then $k = \frac{(By \max + By \min) / 2}{(Bz \max + Bz \min) / 2}$</p> <p>gainValue = $\frac{(By \max + By \min) / 2}{(Bz \max + Bz \min) / 2} * 8192$</p> <ul style="list-style-type: none"> • If you want to adjust the amplitude of the Y-axis, so that the YZ amplitude is the same when the knob is rotated once, set gainSel to 2 <p>Then $k = \frac{(Bz \max + Bz \min) / 2}{(By \max + By \min) / 2}$</p> <p>Gain Value = $\frac{(Bz \max + Bz \min) / 2}{(By \max + By \min) / 2} * 8192$</p> <p>Note: It is recommended to use a configuration with k<1</p> <p>GainSel selects which axis data needs to be modified, k is the multiple and gainValue is k*8192</p>
<p>gainSel</p>	<p>15:14</p>	<p>RW</p>	<p>In rotary applications, the two-axis magnetic field used to calculate the corresponding plane angle will have different amplitudes due to assembly tolerances or off-axis applications. gainSel is the magnetic field amplitude correction bit when the chip is configured as an angle output.</p> <p>gainSel = 0, no amplitude adjustment is made</p> <p>gainSel = 1, the X axis is selected</p> <p>gainSel = 2, the Y axis is selected</p>

KTH5701 series

Low power, high accuracy 3D Hall sensor



			<p>gainSel = 3, the Z axis is selected</p> <p>According to the corresponding application scenario, select the axis that needs to be calibrated for amplitude, and after configuring gainSel, the algorithm for calculating the current plane angle inside the chip will adjust the magnetic field value detected by the selected axis according to the set value of gainValue, and then To achieve the purpose of equalizing the two-axis magnetic field amplitudes used for angle calculation.</p> <p>For example,</p> <ul style="list-style-type: none"> • The YZ plane angle needs to be obtained, and there are various problems such as different YZ axis measurement sensitivity and assembly tolerance, resulting in different YZ two-axis magnetic field amplitudes • The gainSel can choose to perform amplitude calibration on any one of the Y and Z axes
--	--	--	--

0x1C

default: 0x30

15	14	13	12	11	10	9	8	7	6	5	4	3	2	1	0
----	----	----	----	----	----	---	---	---	---	---	---	---	---	---	---

AplaneSel	wakeSel	tempOsr	magnOsr	trigPushSel	extTrig	gain	digCtrl
-----------	---------	---------	---------	-------------	---------	------	---------

Field	Bit	R/W	Description
digCtrl	2:0	RW	Digital Filter Control Parameters.
gain	6:3	RW	Recommend not to modify the default value of this bit, which is gain = 0x6
extTrig	7	RW	When extTrig = 1 and trigPushSel = 0, after the host sends high-level pulse to the BUTT_OUT/TRIG pin of the chip, the chip performs a single measurement, which is equivalent to the host sending a single conversion command to the chip. For details on the gating of measurement items, see measSel.
trigPushSel	8	RW	When trigPushSel = 0 and extTrig = 1, after the host sends high-level pulse to the BUTT_OUT/TRIG pin of the chip, the chip performs a single measurement, which is equivalent to the host sending a single conversion mode command to the chip. For more details see measSel When trigPushSel = 1, the chip enables the button detection function, only configure this register, the BUTT_OUT/TRIG pin will not generate an output signal. Only when the host sends a measurement command to the chip and the chip detects that the selected plane magnetic field increases to the set base value, the BUTT_OUT/TRIG pin will generate an output signal.
magnOsr	10:9	RW	The ADC oversampling rate of magnetic field measurement, corresponding to two bits from low to high, respectively represent 32, 64, 128, and 256

KTH5701 series

Low power, high accuracy 3D Hall sensor



			<p>sampling points at one time.</p> <table border="1"> <thead> <tr> <th>magnOsr</th> <th>0x03</th> <th>0x02</th> <th>0x01</th> <th>0x00</th> </tr> </thead> <tbody> <tr> <td>Number of sampling points</td> <td>256</td> <td>128</td> <td>64</td> <td>32</td> </tr> </tbody> </table> <p>The total number of points taken by the ADC = $32 \times 2^{\text{magnOsr}} \times (2^{\text{digCtrl}} + 2)$, Measurement time of magnetic field signal of a certain axis= (the number of ADC points + 69) * 1 μ s</p>	magnOsr	0x03	0x02	0x01	0x00	Number of sampling points	256	128	64	32		
magnOsr	0x03	0x02	0x01	0x00											
Number of sampling points	256	128	64	32											
tempOsr	12:11	RW	<p>The ADC oversampling rate of temperature measurement, corresponding to two bits from low to high represent 32, 64, 128, and 256 sampling points at a time, respectively.</p> <table border="1"> <thead> <tr> <th>tempOsr</th> <th>0x03</th> <th>0x02</th> <th>0x01</th> <th>0x00</th> </tr> </thead> <tbody> <tr> <td>Number of sampling points</td> <td>256</td> <td>128</td> <td>64</td> <td>32</td> </tr> </tbody> </table> <p>The total number of ADC points = $32 \times 2^{\text{tempOsr}} \times 3$, the temperature signal measurement time = (the number of ADC points + 69) * 1 μ s</p>	tempOsr	0x03	0x02	0x01	0x00	Number of sampling points	256	128	64	32		
tempOsr	0x03	0x02	0x01	0x00											
Number of sampling points	256	128	64	32											
wakeSel	13	RW	<p>The setting bit of the three working modes in wake-up & Sleep mode.</p> <table border="1"> <thead> <tr> <th>wakeSel</th> <th>wakeDiff</th> <th>Brief description of working mode</th> </tr> </thead> <tbody> <tr> <td>0</td> <td>0</td> <td>Baseline value non-update mode</td> </tr> <tr> <td>1</td> <td>0</td> <td>Baseline value update mode</td> </tr> <tr> <td>x</td> <td>1</td> <td>Speed detection mode</td> </tr> </tbody> </table> <p>When the chip is configured in angle output mode (TABZ), the configuration of wakeSel and wakeDiff will no longer work. For details, see the description of the wxyTh bit.</p> <p>When the chip is configured for magnetic flux density output (TXYZ), the corresponding configuration is as follows.</p> <p>When wakeSel = 0, wakeDiff = 0, the chip is in the baseline value non-update mode. If the change of a measurement item exceeds the threshold set in the threshold register (wxyTh, wzTh), the INT pin will be pulled high, but the baseline value will not be updated, it is still the value of this measurement when wake-up & Sleep mode is turned on for the first time.</p> <p>The following is an example process for measuring the change in the Z-axis magnetic field:</p> <ul style="list-style-type: none"> • Set the reference value wakeSel =0, wakeDiff =0 • The host writes the wake-up threshold into the threshold register wzTh • The host sends a wake-up & Sleep mode command (0x28) to the chip, and the chip records the current Z-axis magnetic field value (BZ1) as the baseline value 	wakeSel	wakeDiff	Brief description of working mode	0	0	Baseline value non-update mode	1	0	Baseline value update mode	x	1	Speed detection mode
wakeSel	wakeDiff	Brief description of working mode													
0	0	Baseline value non-update mode													
1	0	Baseline value update mode													
x	1	Speed detection mode													

			<ul style="list-style-type: none"> • The Z-axis magnetic field around the chip changes • When the chip detects that the current Z-axis magnetic field change (the difference between B_{Zn+1} and B_{Z1}) is greater than the set value in $wzTh$, the INT pin is pulled high, but the baseline value remains B_{Z1} <p>When $wakeSel = 1$ and $wakeDiff = 0$, the chip is in the baseline value update mode. If the change of a measurement item exceeds the threshold set in the threshold register ($wxyTh$, $wzTh$), the INT pin will be pulled high, and the current measurement value is updated to a baseline value, otherwise the baseline value is not updated.</p> <p>The following is an example process for measuring the change in the Z-axis magnetic field:</p> <ul style="list-style-type: none"> • Set the reference value $wakeSel = 1$, $wakeDiff = 0$ • The host writes the wake-up threshold into the threshold register $wzTh$ • The host sends a wake-up & Sleep mode command (0x28) to the chip, and the chip records the current Z-axis magnetic field value (B_{Z1}) as the baseline value • The Z-axis magnetic field around the chip changes • When the chip detects that the current Z-axis magnetic field change (the difference between B_{Zn+1} and B_{Z1}) is greater than the set value in $wzTh$, the INT pin is pulled high, and the Z-axis magnetic field value (B_{Zn+1}) at this moment is recorded as baseline value <p>Applicable to all kinds of knob low power consumption scenarios, only wake up the host when the change of the knob magnetic field exceeds the set threshold;</p> <p>When $wakeSel = x$, $wakeDiff = 1$ is the third working mode, see the description of $wakeDiff$ bit (register address is 0x1D) for details</p> <p>Note:</p> <ol style="list-style-type: none"> 1. In wake-up & Sleep mode, after the INT pin is pulled high, only by using the Data Read Frame, the data reads back at one time, and then the Pin is pulled down. The host does not send commands, and the corresponding measurement around the chip. When the item becomes smaller again, the chip will not actively pull down the INT pin signal. 2. When the host controls the $angMagnSel$ register to make the chip in the angle output state, the wake-up & Sleep mode no longer has the above three selection modes, only the reference value does not update mode, and $wxyTh$ no longer stores the xy magnetic field threshold, but the storage expects to reach the wake-up angle threshold. See the $wxyTh$ register description for details.
AplaneSel	15:14	RW	<p>Angle output plane selection.</p> <p>Select the output angle value as the plane magnetic field angle value</p> <p>When $AplaneSel = 0$, the chip outputs the XY plane magnetic field angle value</p>

KTH5701 series

Low power, high accuracy 3D Hall sensor



			<p>When AplaneSel = 1, the chip outputs the YZ plane magnetic field angle value</p> <p>When AplaneSel = 2, the chip outputs the XZ plane magnetic field angle value</p> <p>When AplaneSel = 3, the chip outputs the XY plane magnetic field angle value</p> <p>Note: XY axis and Z axis sensitivity are not the same, if you want to get more accurate YZ plane or XZ plane magnetic field angle value, you need to perform gain adjustment, see the setting of gainSel and gainValue of address 0x1B register for details</p>
--	--	--	--

0x1D:

15	14	13	12	11	10	9	8	7	6	5	4	3	2	1	0
----	----	----	----	----	----	---	---	---	---	---	---	---	---	---	---

xPol	yPol	zPol	absPushEn	wakeDiff	tcmpEn	measSel				measTime				
------	------	------	-----------	----------	--------	---------	--	--	--	----------	--	--	--	--

Field	Bit	R/W	Description
measTime	5:0	RW	<p>In continuous sensing mode and wake-up & Sleep mode, controls the standby time between each measurement. The value set in measTime controls the number of delays, and 1 lsb corresponds to a waiting delay of 20ms. The value in measTime applies as many delays as the decimal value is set.</p> <p>If measTime = 0x05, the waiting time between two measurements of the chip is 5 times of 20ms delay, 5*20ms=100ms.</p>
measSel	9:6	RW	<p>Measurement selection communication signal, when the host sends any of the three measurement mode commands to the chip, where the four bits of the measurement item are 0, measSel is selected as the default measurement selection communication signal.</p> <p>These four bits correspond to the strobe order: measSel[3:0] ZYXT from high to low</p> <p>If measSel[3:0]=0x03 and the host sends a continuous sensing mode command to the chip (0x10), the chip measures XT two items determined by the parameters configured in measSel, BUTT_OUT/trig pin is configured for the trig function.</p> <p>Note: After the host sends high-level pulse to the BUTT_OUT/TRIG pin of the chip, the chip performs a Single Conversion Mode, which is equivalent to the host sending a Single measurement command to the chip, and the switching of ZYXT is determined by measSel.</p> <p>The four bits in measSel [3:0] correspond to the selection of the measured signal, which is ZYXT from high to low. As measSel [3:0]= 0x03, both</p>

KTH5701 series

Low power, high accuracy 3D Hall sensor



			measurement channels XT are selected.
tcmpEn	10	RW	Temperature calibration enables signal. When tcmpEn =1, temperature calibration is enabled for magnetic field output. When tcmpEn =0, magnetic field raw data output. The BIT does not control the output calibration of temperature values.
wakeDiff	11	RW	When wakeDiff = 1, the chip is in Wake-up & Sleep Mode, and the difference between the two adjacent measurements is detected, and when it is greater than the threshold set in the corresponding register, the INT pin is pulled high.
absPushEn	12	RW	Button detection algorithm enable item. When absPushEn=1, use the absolute magnetic field detection button function. The magnetic field threshold setting is detailed in the address 0x1F register.
zPol	13	RW	Z-axis polarity control signal. When zPol = 0, the chip output value is the measured value. When zPol =1, the Z-axis output value of the chip = 2^{16} - the current measurement value.
yPol	14	RW	Y-axis polarity control signal. When yPol = 0, the chip output value is the measured value. When yPol =1, the Y-axis output value of the chip = 2^{16} - the current measurement value.
xPol	15	RW	x-axis polarity control signal. When xPol = 0, the chip output value is the measured value. When xPol =1, the X-axis output value of the chip = 2^{16} - the current measurement value.

0x1E:

15	14	13	12	11	10	9	8	7	6	5	4	3	2	1	0
----	----	----	----	----	----	---	---	---	---	---	---	---	---	---	---

ang MagnSel	Zero[15:1]														
----------------	------------	--	--	--	--	--	--	--	--	--	--	--	--	--	--

Field	Bit	R/W	Description
Zero[15:1]	14:0	RW	Set the first 15 bits of the zero point value of the angle output. Invert the value that needs to be set to zero and add 1, and write 15bits higher into

KTH5701 series

Low power, high accuracy 3D Hall sensor



			Zero[15:1]. For example, the angle 0x01AA needs to be set to zero point, then the value of zero is 0x7F2B.
angMagnSel	15	RW	<p>The host can use data Read Frame to read back the measurement status and all measurement data at one time.</p> <p>When angMagnSel = 1: the last four bits of the read back command select ZBAT data, Z: the magnetic flux density of the Z axis, B: The corresponding quantity of the plane magnetic field calculated by CORDIC algorithm from the two axes of the selected plane, A: Plane Angle, T: current temperature. For details, please refer to 11.2 TABZ read back mode corresponding description.</p> <p>When angMagnSel = 0: the last four bits of the read back command select ZYXT data;</p>

0x1F:

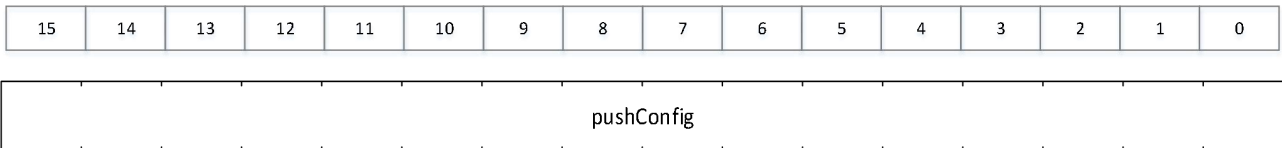

Field	Bit	R/W	Description
pushConfig	15:0	RW	<p>Push button function configuration register.</p> <p>When absPushEn=1, the detection benchmark of the push button function is the select plane magnetic flux density value written in pushConfig.</p> <p>The following is an example of the XY plane:</p> <p>Before pressing, the chip detects that the magnetic flux density of the XY plane is 0x3000. After the button is pressed, the magnetic flux density of the XY plane detected by the chip increases to 0x4000. In the current application, it is hoped that when the chip detects that the magnetic flux density of the XY plane exceeds 0x4000, the chip's buttOut pin is pulled high, then fill 0x4000 in pushConfig. The detected XY plane magnetic flux density in the current configuration can be read back in the TABZ format in Data Read Frame.</p> <p>When absPushEn=0, pushConfig[15:13] is used to set the XY plane magnetic field detection threshold. When the magnetic field is greater than the magnetic field set in pushConfig[15:13], the returned Status magnDet position one.</p> <p>pushConfig[15:13] is calculated as follows:</p> <p>The reference value is 0x1000 and pushConfig[15:13] is set to how many bits to shift to the right. For example, pushConfig[15:13] = 0x4, then the reference value is 0x1000 and shifted to the right by four bits, that is, 0x0100</p>

17 OTP Programming

1.6ms time to program an address bit, only one address can be programmed at a time

The following is the specific programming process 5.5~5.7V

KTH5701 series

Low power, high accuracy 3D Hall sensor



VDD Power Supply 5.5~5.7V

VDDIO Power Supply 3.3V

- Step 1: Write 0x3337 to the address 0x0C register
- Step 2: Write the value that needs to be programmed to the address 0x0B register (if you need to write 0x19 to the 0xffff register, write the 0xffff here)
- Step 3: Write the program current value 0x0043 to the address 0x09 register
- Step 4: Write the register address to be programmed to the register address 0x0A (if you need to write 0xffff to the 0x19 register, write 0x19 here)
- Step 5: Write 0x0001 to the address 0x08 register and start programming
- Step 6: The programming time is about 1.6ms, the next step can be carried out after the programming is completed, if you do not need to program again, you need to clear the register value of the address 0x09 to 0x0C to prevent programming errors.

Next, check whether the programming is successful

- Step 1: Write 0x3337 to the address 0x0C register
- Step 2: Write 0x0050 to the address 0x09 register
- Step 3: Write 0x0001 to the address 0x07 register
- Step 4: Read back the register value that was programmed to confirm whether the programming was successful.

18 QFN_16PIN Package Dimensions

18.1 QFN3x3-16L package

Unit: mm

KTH5701 series

Low power, high accuracy 3D Hall sensor

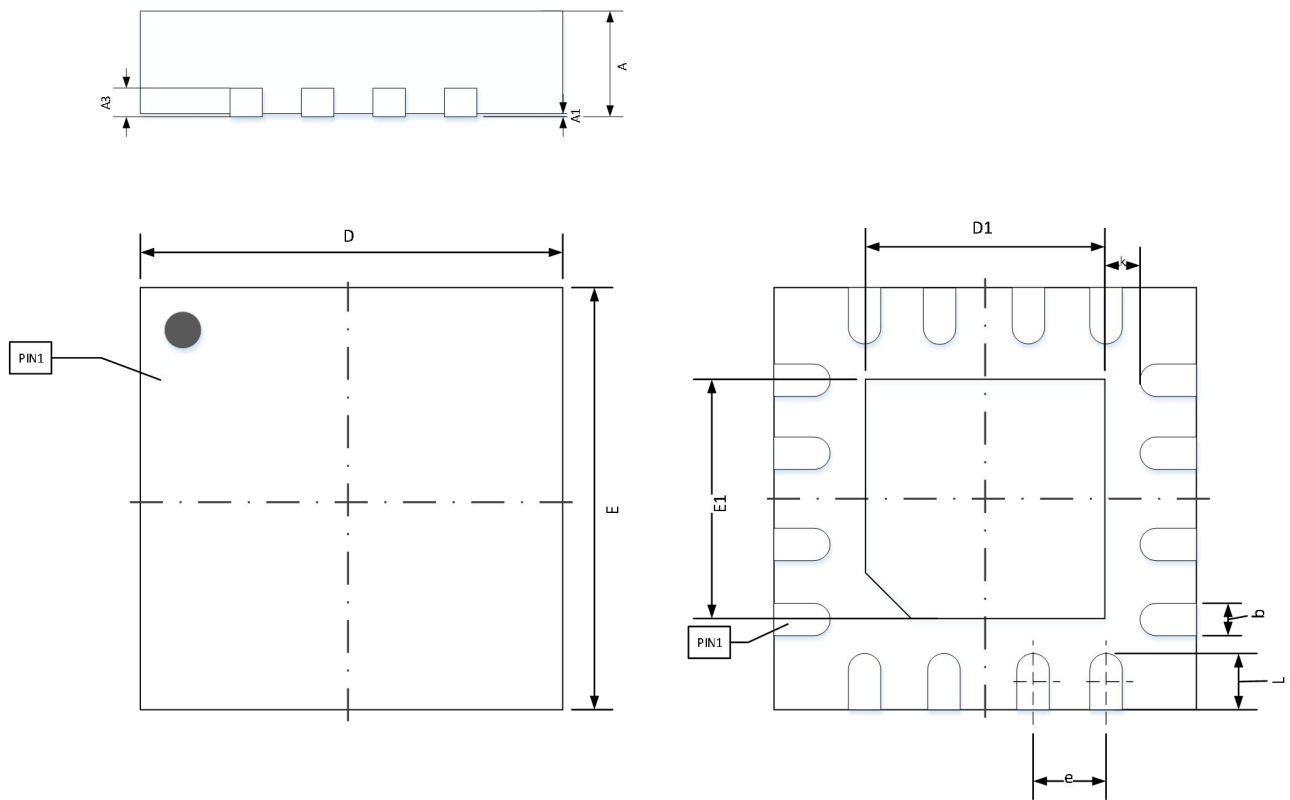

Figure 18-1. QFN_16PIN Package Dimensions

Symbol	Unit: mm	
	Min.	Max.
A	0.700	0.800
A1	0.000	0.050
A3	0.203REF.	
D	2.900	3.100
E	2.900	3.100
D1	1.350	1.550
E1	1.350	1.550
k	0.375REF.	
b	0.200	0.300
e	0.500BSC.	
l	0.300	0.500

KTH5701 series

Low power, high accuracy 3D Hall sensor



18.2 DFN2x2.5-8L package

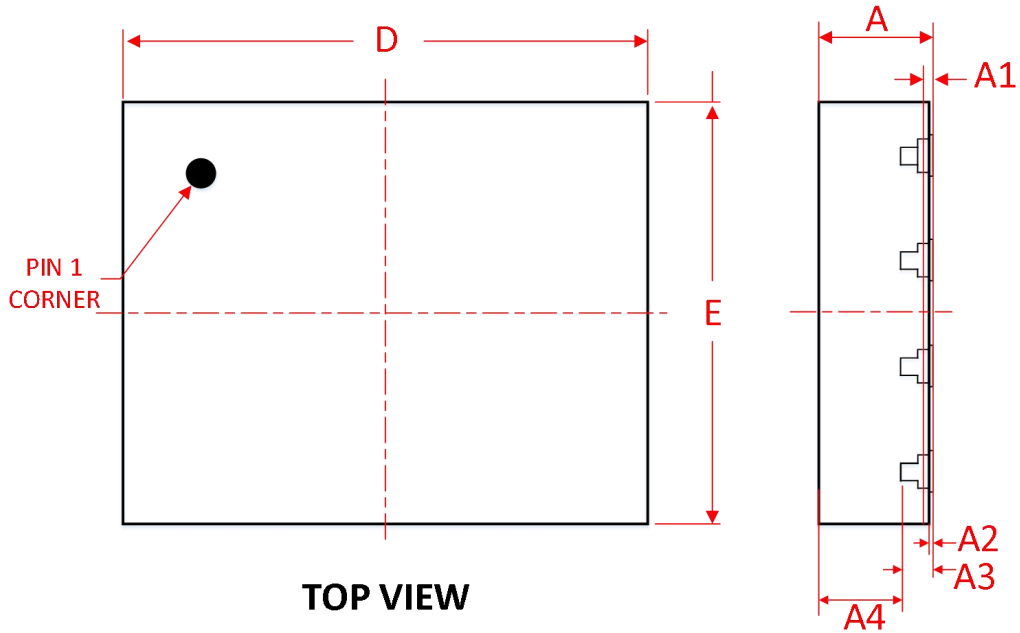

TOP VIEW

SIDE VIEW

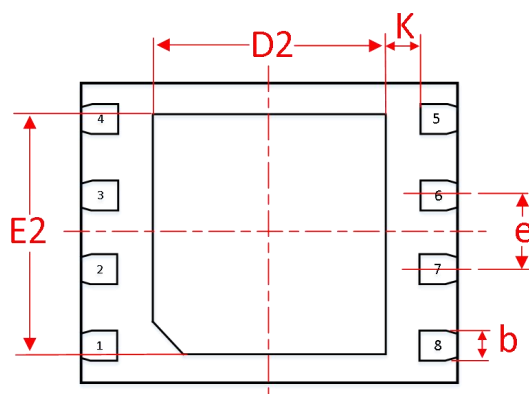

BOTTOM VIEW

SYMBOL	MILLIMETER		
	MIN	NOM	MAX
D	2.5BSC		
E	2BSC		
A	0.50	0.55	0.60
A1	0.05		
A2	0	0.02	0.05
A3	0.152REF		
A4	-	0.4	-
D2	1.46	1.56	1.66
E2	1.5	1.6	1.7
K	0.22REF		
e	0.5BSC		
b	0.15	0.2	0.25

KTH5701 series

Low power, high accuracy 3D Hall sensor



19 Reference Circuit

Note: In order to ensure the stability of communication, be sure to use a combination capacitor of $0.1 \mu\text{f}$ and $10 \mu\text{f}$, and the capacitor is as close as possible to the chip VDD. The A0 and A1 pins are grounded when not in use.

19.1 QFN3x3-16L package SPI

$C1 = C3 = 0.1 \mu\text{F}$
 $C2 = C4 = 10 \mu\text{F}$
It is recommended that all NC pins be grounded

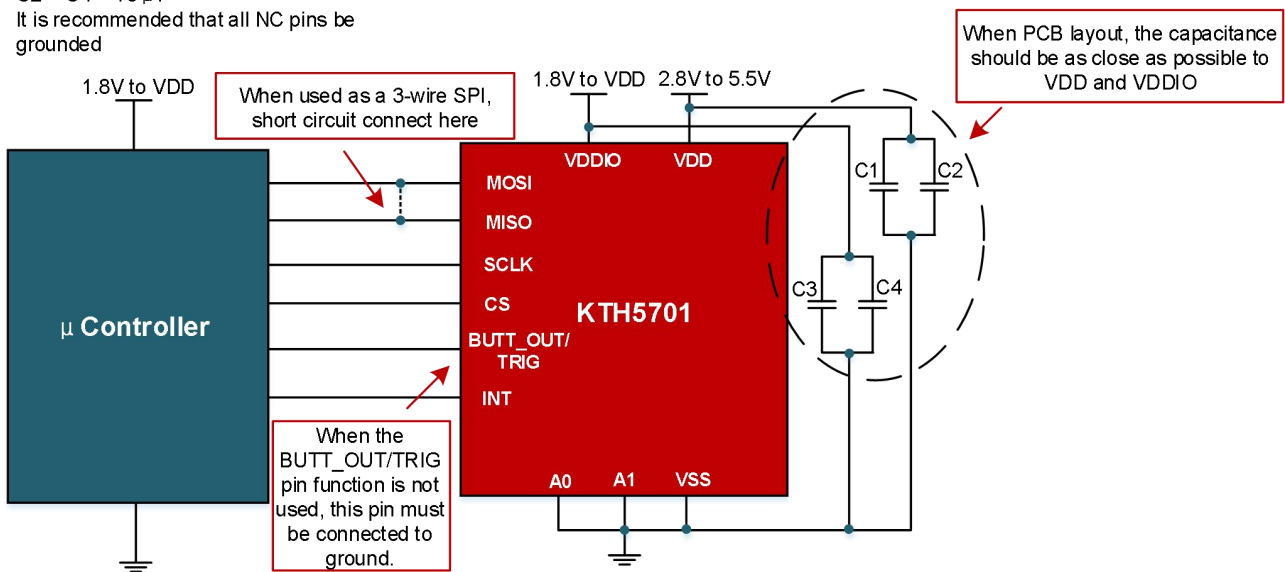

KTH5701 series

Low power, high accuracy 3D Hall sensor



19.2 QFN3x3-16L package I2C

A1	A0	I2C Address
VSS	VSS	1101000R / W
VSS	VDD	1101001R / W
VDD	VSS	1101010R / W
VDD	VDD	1101011R / W

R1 = R2 = 4.7k ohm
 C1 = C3 = 0.1 μ F
 C2 = C4 = 10 μ F
 It is recommended that all NC pins be grounded

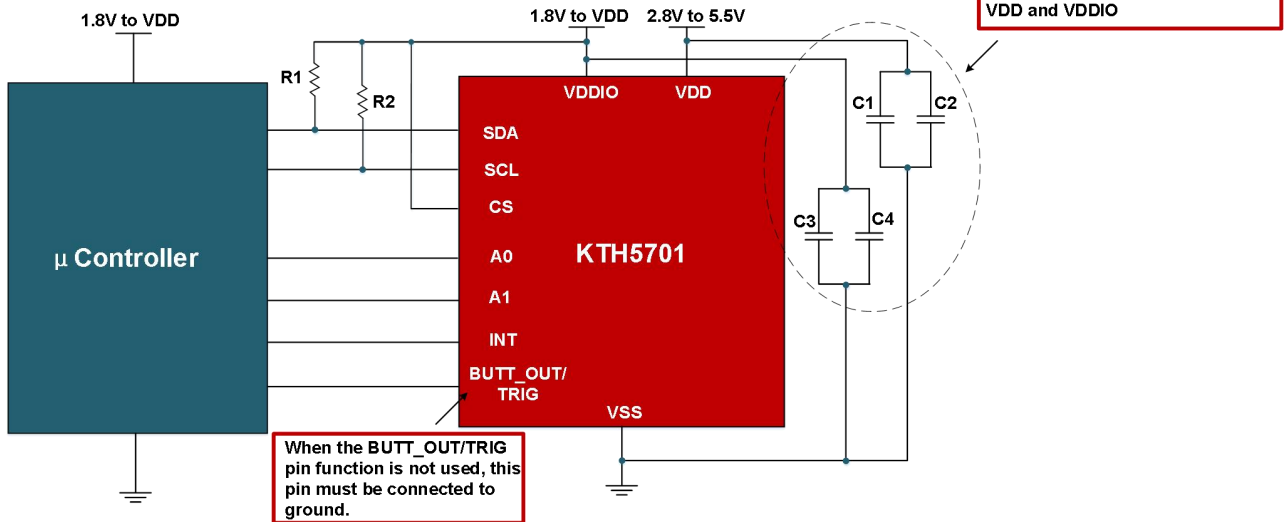

19.3 DFN2x2.5-8L package I2C

R1 = R2 = 4.7k ohm
 C1 = C3 = 0.1 μ F
 C2 = C4 = 10 μ F
 I2C Address : 1101000R / W

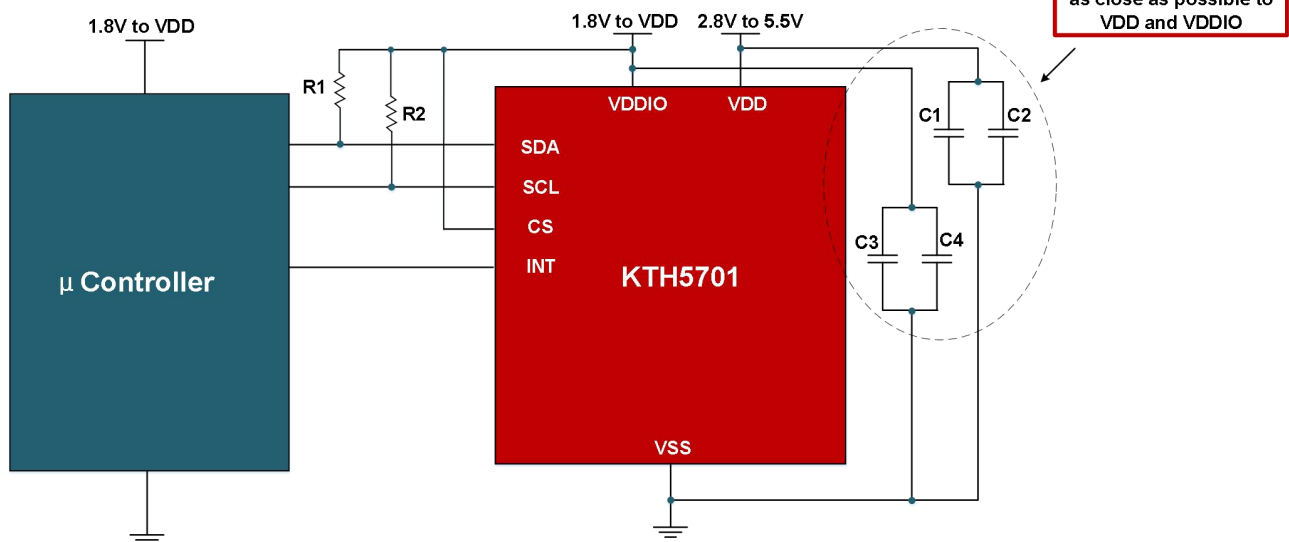

20 Order Information

KTH5701 series

Low power, high accuracy 3D Hall sensor



Part Numbers	Package	Temperature	Application	Number of Pins
KTH5701AQ2QNS	QFN3x3-16L	-40°C ~ +105°C	Industrial Grade	16
KTH5701AQ3QNS	QFN3x3-16L	-40°C ~ +85°C	Consumer Grade	16
KTH5701AQ2DNE	DFN2x2.5-8L	-40°C ~ +105°C	Industrial Grade	8
KTH5701AQ3DNE	DFN2x2.5-8L	-40°C ~ +85°C	Consumer Grade	8

21 Strap and Reel Information

21.1 QFN3x3-16L

KTH5701 series

Low power, high accuracy 3D Hall sensor



TAPE AND REEL INFORMATION

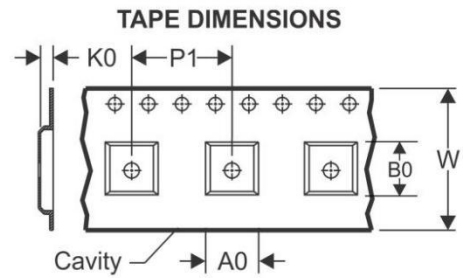
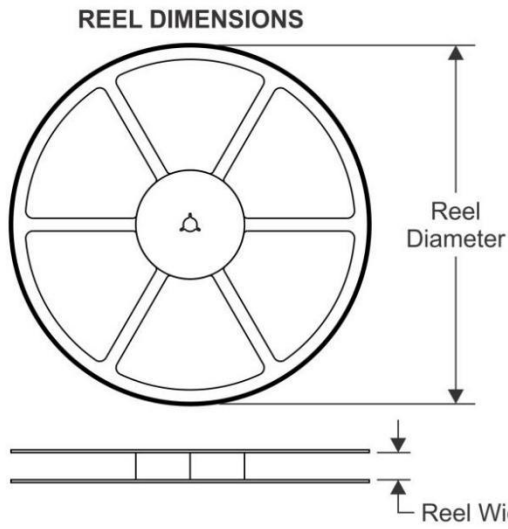

A0	Dimension designed to accommodate the component width
B0	Dimension designed to accommodate the component length
K0	Dimension designed to accommodate the component thickness
W	Overall width of the carrier tape
P1	Pitch between successive cavity centers

QUADRANT ASSIGNMENTS FOR PIN 1 ORIENTATION IN TAPE

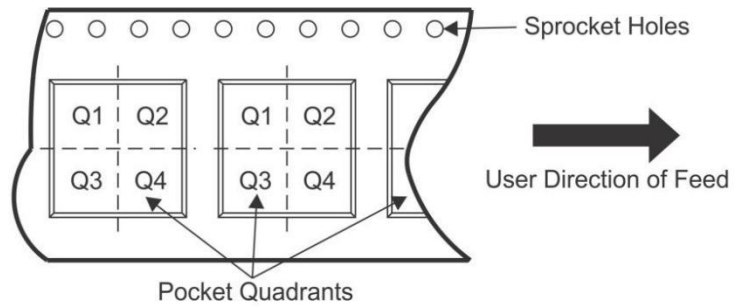

Package Type	Pins	SPQ	Reel Diameter	Reel Inside Width	A0 (mm)	B0 (mm)	K0 (mm)	P1 (mm)	W (mm)	Pin1 Direction
QFN3*3-16L	16	5000	330	12.4	3.35	3.35	1.13	8.00	12.00	Q1

KTH5701 series

Low power, high accuracy 3D Hall sensor



21.2 DFN2x2.5-8L

REEL DIMENSIONS

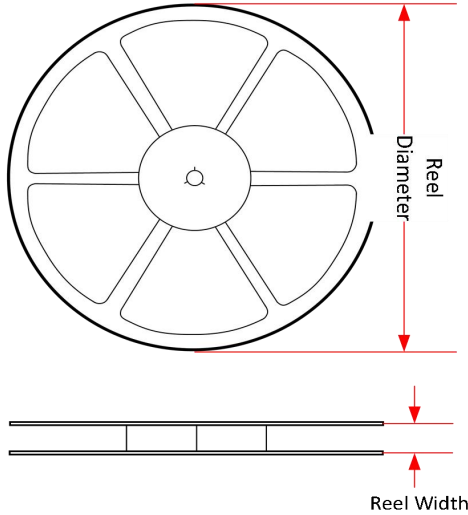

TAPE DIMENSIONS

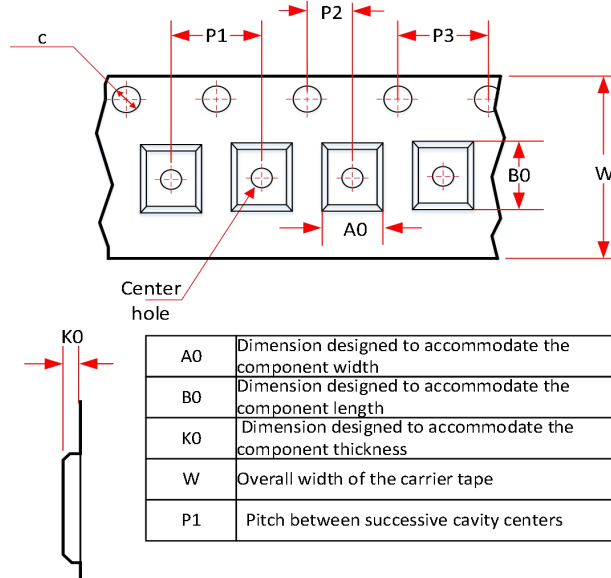

QUADRANT ASSIGNMENTS FOR PIN 1 ORIENTATION IN TAPE

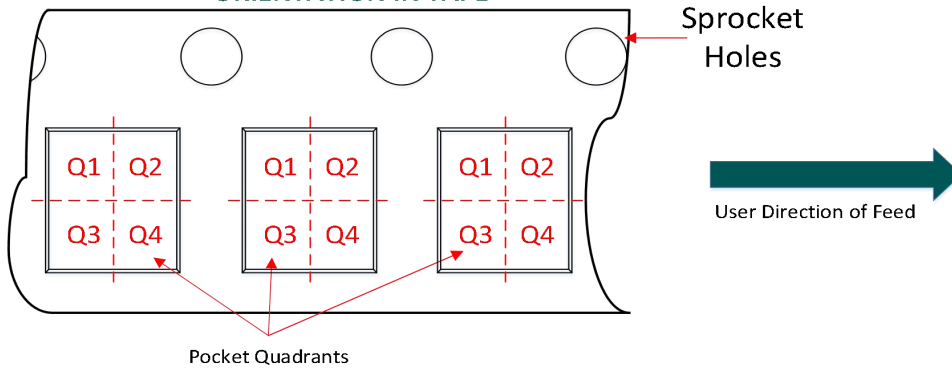

Package Type	Pins	SPQ	Reel Diameter	Reel Inside Width	A0 (mm)	B0 (mm)	K0 (mm)	P1 (mm)	P2 (mm)	P3 (mm)	c 直径 (mm)	W (mm)	Pin1 方向
DFN2x2.5-8L	8	4000	180	9.5	2.25	2.75	0.7	4.00	2.00	4.00	1.5	8.00	Q2